

Clutch housing

Drive element accessories

Connection options

Direct drive preparation

Connecting options <i>Direct drive</i>	LES 4	LES 6	LES 5	Angular gear fixing 0°	Angular gear fixing 90°
MS 200 HT-2 DC 100 EC 60	Connection via coupling casing 1 <i>short sleeve</i> with adequate shaft coupling			Coupling casing 1 <i>long sleeve</i>	
MS 600 HT MS 900 HT EC 86	Connection via coupling casing 2 <i>short sleeve</i> with adequate shaft coupling			Coupling casing 2 <i>long sleeve</i>	
Angular gear fixing 0°	split coupling casing <i>short sleeve</i> with adequate shaft coupling			Connection via transmission shaft set	
Angular gear fixing 90°	split coupling casing <i>short sleeve</i> with adequate shaft coupling				

Ordering overview

Clutch housing

Clutch housing 1

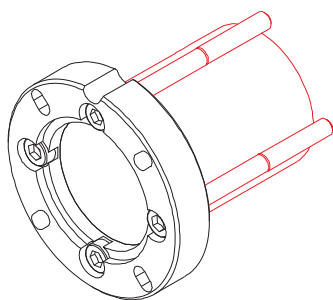

short sleeve
Part no.: 218 100 0001

long sleeve
Part no.: 218 100 0002

Clutch housing 2

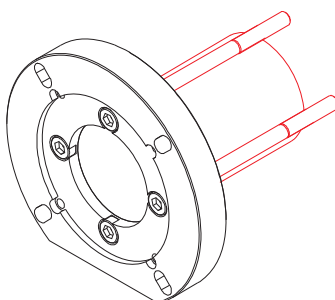

short sleeve
Part no.: 218 100 1001

long sleeve
Part no.: 218 100 1002

Split clutch housing

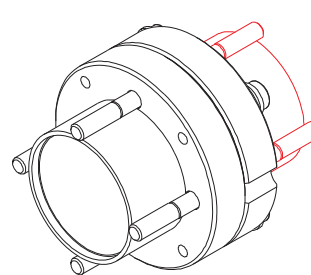

short sleeve
Part no.: 218 100 2001

long sleeve
Part no.: 218 100 2002

Clutches

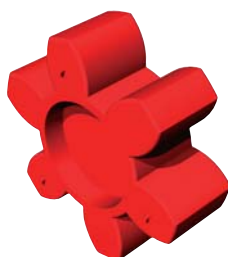
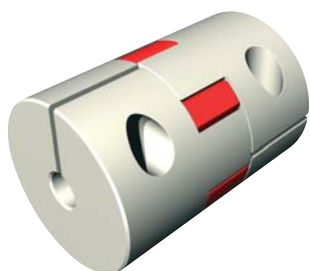

coupling	Item no.:	d ₁	d ₂
20/30	218 001 5060	5,0	6,0
	218 001 9999	from 4 to 7 mm	
30/40	218 002 6380	6,35	8,0
	218 002 8080	8,0	8,0
	218 002 9999	from 6 to 13 mm	
40/60	218 003 9580	9,52	8,0
	218 003 9999	from 8 to 18 mm	

Clutch housing

Drive element accessories

Dimensioned drawing

Coupling casing 1

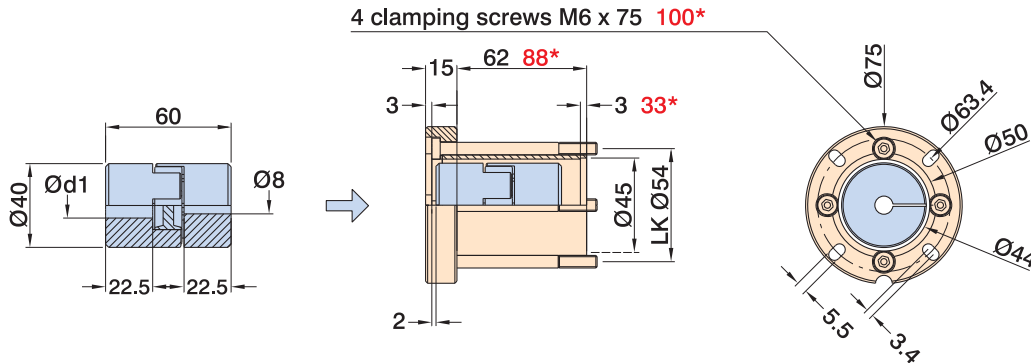

**) Measures refer to the dimensions with long sleeves*
 d1 = engine shaft diameter 6.35/8/9 mm
 Suitable shaft coupling WK 40/60 on page 2-68 (not included in scope of delivery)

Dimensioned drawing

Coupling casing 2

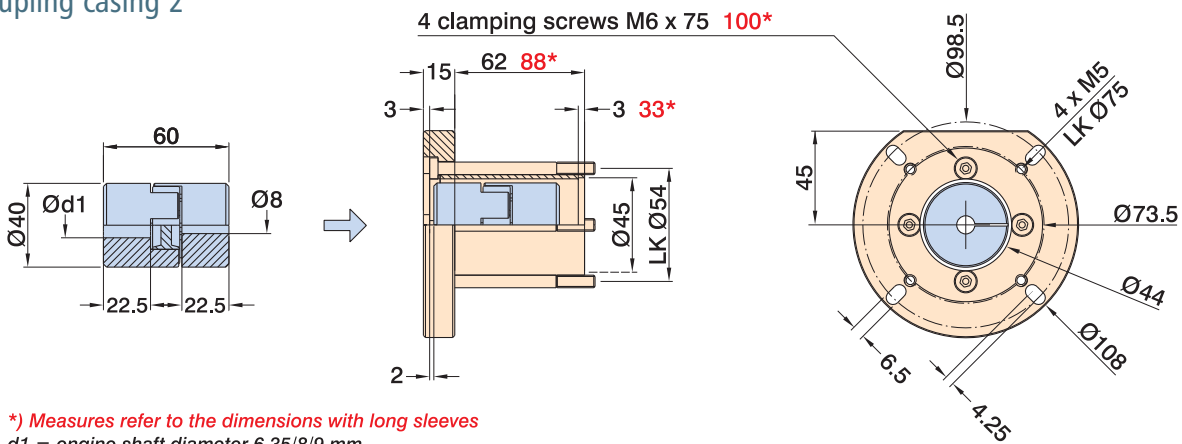

**) Measures refer to the dimensions with long sleeves*
 d1 = engine shaft diameter 6.35/8/9 mm
 Suitable shaft coupling WK 40/60 on page 2-68 (not included in scope of delivery)

Dimensioned drawing

Split coupling casing

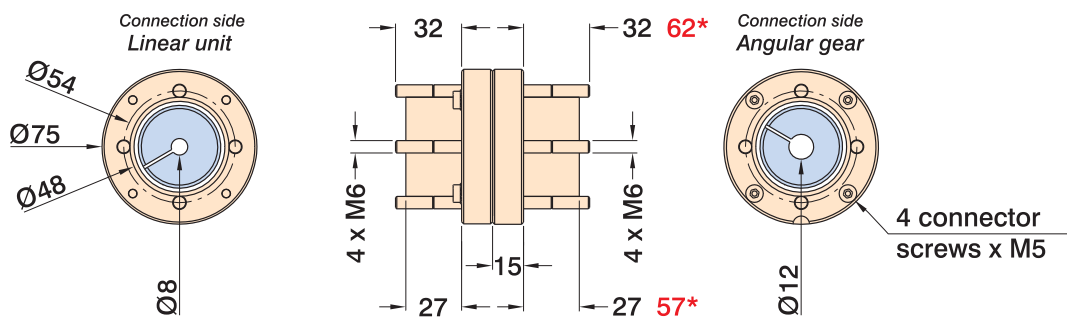

**) Measures refer to the dimensions with long sleeves*
 Suitable shaft coupling WK 40/60 on page 2-68 (not included in scope of delivery)