

Linear units with toothed belt drive

LEZ 1

Guides
and shaft slides
also available stainless.



with shaft slide



with trolley

Features

- Aluminium profile, miniature linear guide LFS-8-2
- No-play feed with toothed belt drive
 - toothed belt with 3 mm interval, width 9 mm
- Feed per turn: 60 mm
- Repeatability less than or equal to ± 0.2 mm
- Max. feed. 1.5 m/s

Accessories can be found on pages 2-94.

Options:

- Special 100 mm raster lengths to order, max. 6000 mm
- Securing with integrated M6 tapped rail, raster 50 mm

Ordering key

232 005 XXXX

Drives/Slides

Trolley

- 8 = without motor, with shaft slide
- 9 = without motor, with trolley

Profile lengths LFS-8-2 (mm)

- 298, 398, 498, 598, 675, 698, 798, 998, 1498, 1798, 1998, 2498, 2998
 (e. g. 398 mm = 040
 675 mm = 068)
 Option: up to 6000 mm

Technical specification

Belt type.....HTD 3M, width 9 mm
 Slide weight.....0.430 kg
 Weight without drive module.....1000 mm = 3 kg
 specific weight of the toothed belt.....0.0225 kg/m
 Trolley weight.....1.03 kg
 specific guide weight.....0.200 kg/100 mm
 Effective \varnothing of the synchronous disks.....19.10 mm
 Moment of inertia of the synchronous discs..... 5.585×10^{-7} kgm²
 Feed per turn.....60 mm

Drive module with stepper motor MS-045 HT



Drive module with stepper motor MS-135 HT



Load diagram

Permitted accelerated weights relative to the belt strength.*

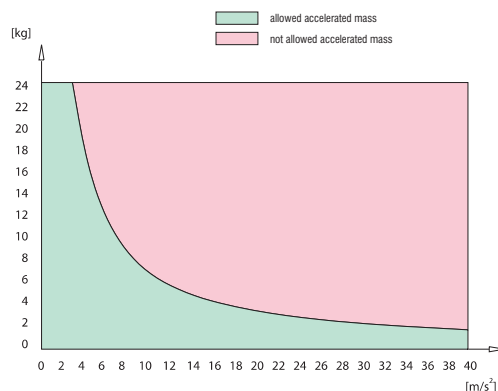

* with vertical construction, the acceleration due to gravity ($g = 9.81$ m/s²) must be taken into account

Bending data is on page 2-23.

Linear units

with toothed belt drive

LEZ 1

Dimensioned drawings

without motor, with shaft slides

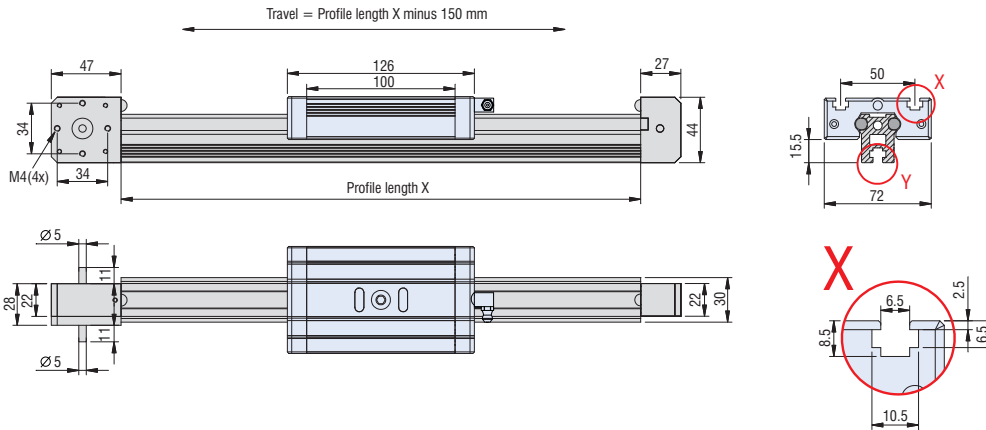

without motor, with trolley

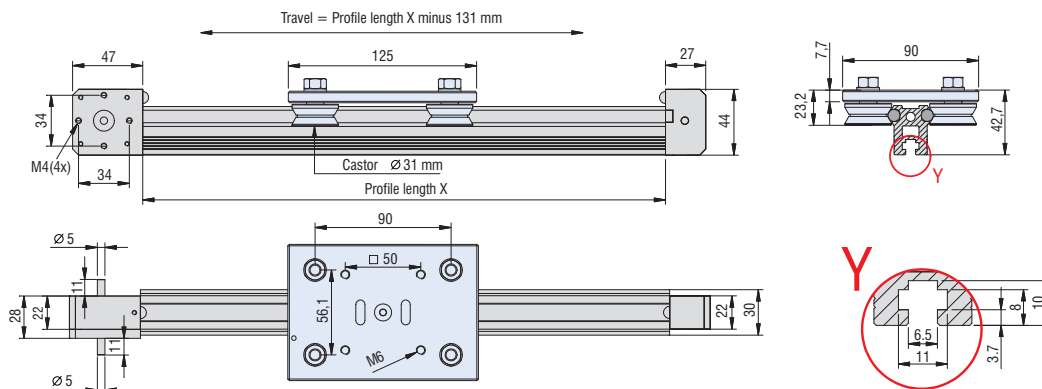

Motor modules (Motor pin assignments are on Page 2-70.)

Drive module with stepper motor
MS-045 HT (direct drive)
Feed: 60 mm / turn

Part no.: **396048 3015**

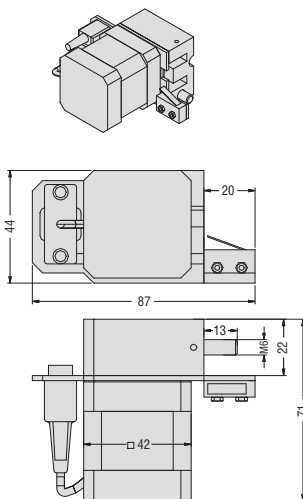

Total length with motor module: profile length + 94 mm

Drive module with stepper motor
MS-045 HT (reduction 2:1)
Feed: 30 mm / turn

Part no.: **396049 3015**

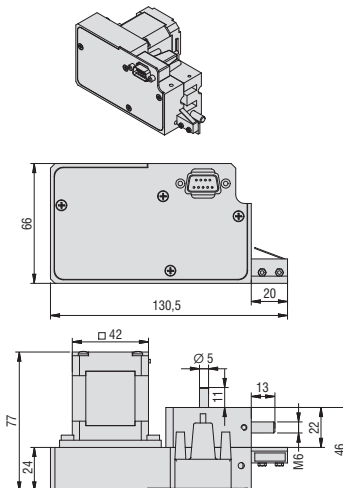

Total length with motor module: profile length + 138 mm

Drive module with stepper motor
MS-135 HT (reduction 2:1)
Feed: 30 mm / turn

Part no.: **396056 3015**

