



isel[®] *From Components to Systems*

EUROSCOOTER II

with **CE-CERTIFICATION**
and **ROAD APPROVAL**

ES-135



- EuroScooter2 with 1000 W wheel hub motor, maximum speed 15 km/h, range approx. 40 km, weight ES 135: 95 kg / ES 175: 130 kg
- solid steel frame with double base plate and anti slip mat for battery pack 48 V / 20 / 30 Ah with motor control system
- shifter for 1 speed forward and 1 reverse gear, LED headlights, LED backlight, key switch and charger
- front wheel Ø16 inch with two hydraulic disc brake as well as an electric brake with energy recovery
- rear wheels Ø10 inch, guard plate with license number; maximum permitted total weight 250 kg

ES-175



hydraulic disc brake
with parking brake



detachable
LED spotlight with
battery operation



Key switch, forward / reverse function key
and charging status

...for best quality and price...

ES-135

ES-175



DIMENSIONED DRAWING

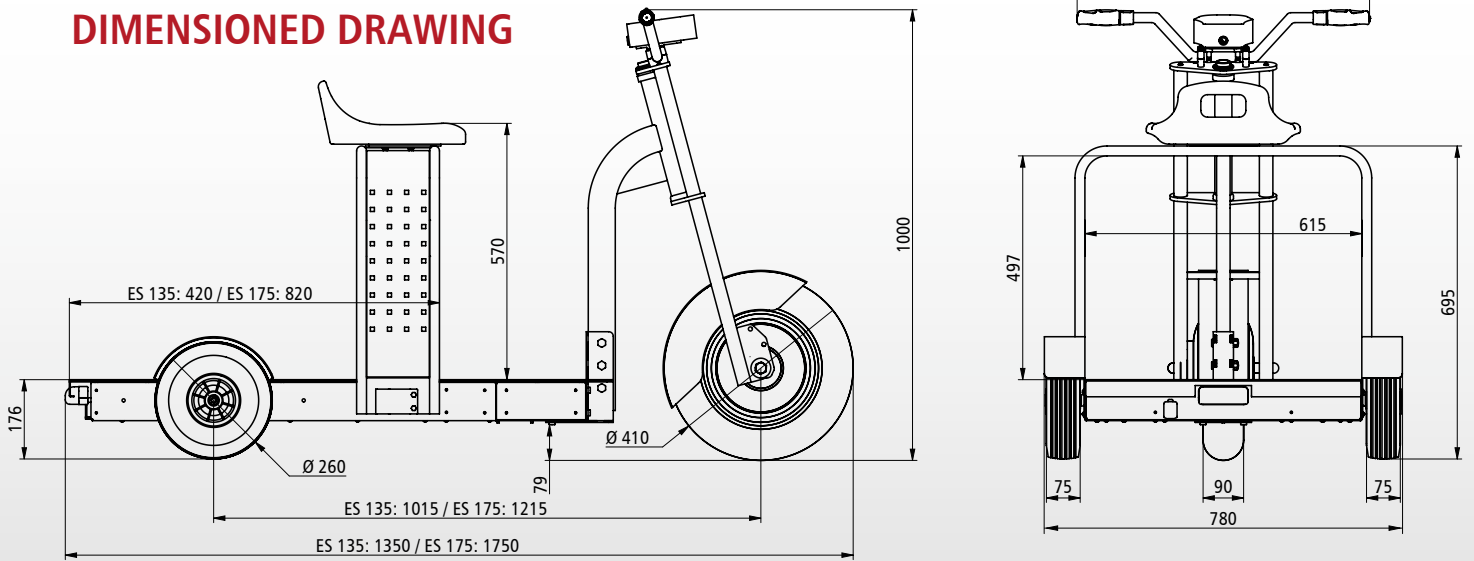

Technical specifications subject to change.
91020604-01_EuroScooter

ORDER DATA

EuroScooter2, internally usage	dimensions LxWxH [mm]	loading area BxL [mm]
ES 135	1350 x 780 x 1000	600 x 550
ES 175	1750 x 780 x 1000	600 x 940

EuroScooter2, with MOT approval	dimensions LxWxH [mm]	loading area BxL [mm]
ES 135	1350 x 780 x 1000	600 x 550
ES 175	1750 x 780 x 1000	600 x 940

example with stable toolbox



example with euro-containers, available in various sizes



iselGermanyAG
a company of the isel group

contact: Volker Zulauf
tel: +49 (0) 6659 / 981-750
fax: +49 (0) 6659 / 981-776

mobil: 0151 19552786
volker.zulauf@isel.com

www.isel.com