



IT116 flash
IT116 mini

Operating Instruction

All information, technical data and dimensions contained in this booklet correspond to the technical state at the moment of publication. However, possible misprints or mistakes cannot be ruled out. We will appreciate all suggestions for improvement and error notes.

We would like to point out that all used software and hardware names of the respective companies generally are subject to protection by brand, trademark and patent law.

All rights reserved. It is prohibited to process, duplicate or reproduce this booklet partially or on the whole in any form (print, copy, or other procedure) without written permission of **isel Germany GmbH**.

This booklet has been translated from the original German version into English language. It does not lay claim to completeness nor flawlessness. In case of doubt the German original has validity.

info

isel Germany GmbH controllers are concurrent with CE norms and marked accordingly. Commissioning of all other parts or components, for which CE safety regulations apply, is prohibited until all respective requests are met.

info

isel Germany GmbH as the manufacturer cannot take over guarantee if you change the controller in any way.

info

The EMC test is valid only for the controller's original configuration ex works, i.e. the delivery state.

Manufacturer: **isel Germany GmbH**
Bürgermeister-Ebert-Straße
40 D-36124 Eichenzell

Tel.: (06659) 981-0
Fax: (06659) 981-776
Email: info@isel.com
<https://www.isel.com>

Index revision	Date of change	Reason of change	Amended by
c	22/07/2019	Layout, RoHS	KJ
b	10/11/2015	Addition technical Data	RL
a	16/09/2015	Addition 381017 SDZ 6185	RL
	07/2014	First edition	

<https://www.isel.com/service/download>

Table of contents

1	Introduction.....	4
2	Scope of delivery	6
3	Technical data.....	7
4	Control and notification elements.....	8
4.1	Front side IT116 mini / IT116 flash	8
4.2	Back side IT116 mini / IT116 flash.....	10
4.3	DIP - switch settings	15
4.3.1	DIP-switch settings on IT116 flash.....	16
4.3.2	DIP switch settings on IT116 flash 381017 SDZ6185.....	18
4.3.3	DIP-switch settings on IT116 mini.....	19
5	Electrical connection and initial operation.....	20
6	PALPC: User programming for CNC mode and download	21
6.1	Install programming software PALPC.exe	21
6.2	User programming for CNC mode and download	23
7	Declaration of Conformity.....	25
8	Bibliography.....	26
9	Index	26

Table of figures

figure 1–	motor module connector 2- phase stepper motor	11
figure 2 –	connection for external security circuit.....	12
figure 5 –	impulse control connection	14
figure 6 –	digital inputs wiring	14
figure 7 –	digital outputs wiring	15

1 Introduction

The controllers IT116 flash / IT116 mini are powerful 1-axis-controllers for numerically controlled motion of a linear or rotary axis with a 2-phase-stepper motor. The controller has each four binary inputs / outputs. For communication between a PC / Notebook (under Windows operation system) and the controller a serial interface (RS232) is used.

The microprocessor (DSP) based controller includes an internal flash memory with a size of 128 KBytes for storing the firmware and the application program. The controller is prepared for loading application programs from USB memory stick (**future option**).

The controllers IT116 flash / IT116 mini have the feature of micro stepping:

- IT116 flash: 128 micro steps per full step
- IT116 mini: 8 micro steps per full step

This feature allows a very smooth motion of the connected 2-phase-stepper motor. The automatic current draw down reduces power dissipation as in the amplifier as in the stepper motor.

The peak current is 3,3A (IT116 mini) resp. 4,2A (IT116 flash), it can be reduced by DIP switch to conform parameters of different stepper motors.

Using the impulse inputs for external Start, Stop and Reset those functions can be remote controlled by an operator panel or master controller like a PLC.

The integrated security circuit with **safety category 3** has also a remote interface for integration in a higher-level security circuit.

Safety symbols

**Attention**

This symbol signalizes that there is danger for persons life and health.

**Danger**

This symbol signalizes that there is danger for material, machine and environment.

**Information**

This symbol signalizes important information.

Safety instructions

- The 1-axis-controllers IT116 flash / IT116 mini are designed to current technical and recognized rules.
- The device may only be used if it is in correct condition. Any faults have to be eliminated immediately. Neither children nor non-authorized persons are allowed to put the device into operation.
- The device may only be used for the intended use: control of a linear or rotational axis with brushed (MC1-10), brushless (MC1-20) DC servo motors or 3-phase stepper motors (MC1-30) up to 500 W and integrated incremental measurement system (encoder) in CNC or DNC mode.
- All work with the 1-axis controller IT116 flash / IT116 mini, especially initial operation, installation as well as external wiring must be executed by authorized personal regarding electrical industry rules and accident prevention regulations.
- Assembly and use of operating material has to be according to machine directive 2006/42/EC and Low voltage directive 2006/95/EC. In case of in proper use even the observation the respective rules and standards does not protect against physical damages and damage to property.
- Ambient temperature: +5°C to +40°C
- Storage temperature: -25°C to +70°C
- Pay attention that there is enough free zone on the louvers for air circulation. Ignoring this fact causes overheat and potential defect of the controller.
- Do not expose the device to high humidity or high vibrations.
- Please take care of the instruction manual. Be sure that all users know the instructions.
- Ignoring the instruction manual can lead to damage, heavy physical damage or to death.

2 Scope of delivery

The controller will be delivered with the following components:

IT116 flash (Part.-No. 381016 (230VAC), 381016 0115 (115VAC))

- Stepper motor drive module in 22 TE-cartridge case, incl. power supply unit 115V/230VAC
- Opposite connector controller side (DIN 41612 F24/H7 socket connector, solder pin)
- Opposite connector power supply unit side (DIN 41612 H15 socket connector, solder pin)
- Serial interface cable for IBM compatible PCs (9 pin. Sub D-female – RJ45-male)
- Operating instruction

IT116 mini (Part.-No. 381017)

- Stepper motor drive module in 22 TE-cartridge case, incl. power supply unit 115V/230VAC
- Opposite connector controller side (DIN 41612 F24/H7 socket connector, solder pin)
- Opposite connector power supply unit side (DIN 41612 H15 socket connector, solder pin)
- Serial interface cable for IBM compatible PCs (9 pin. Sub D-female – RJ45-male)
- Operating instruction

3 Technical data



	IT116 flash	IT116 mini	IT116 flash 381017 SDZ6185
dimensions (W x H x D):	105 x 111 x 320	105 x 111 x 200	
weight:	2380 g	1125 g	
safety class:	IP20	IP20	
power supply:	115/230VAC 50/60 Hz (switchable)	90 - 264VAC 50/60Hz	
power consumption:	150 W	125 W	
rated current:	1.5 A	1.2 A	
ambient temperature:	+5°C - +40°C	+5°C - +40°C	
storage temperature:	-20°C - +65°C	-20°C - +65°C	
humidity:	maximum 80% not condensing	maximum 80% not condensing	
CPU:	32Bit CPU kernel		
program memory:	128KByte flash		
communication:	RS232 (19200 baud, 8 data bit, 1 stop bit, no parity)		
digital inputs:	4 via optocoupler (input current ca. 8mA)		
digital outputs:	4 relays, close contact 24VDC/0.5 A max		
maximum input frequency:	40 kHz (full step)	15 kHz (full step)	
stop category:	0		
fuse:	2 x 2 A/250V time lag HBC	2 x 1 A/250V time lag HBC	

4 Control and notification elements

4.1 Front side IT116 mini / IT116 flash

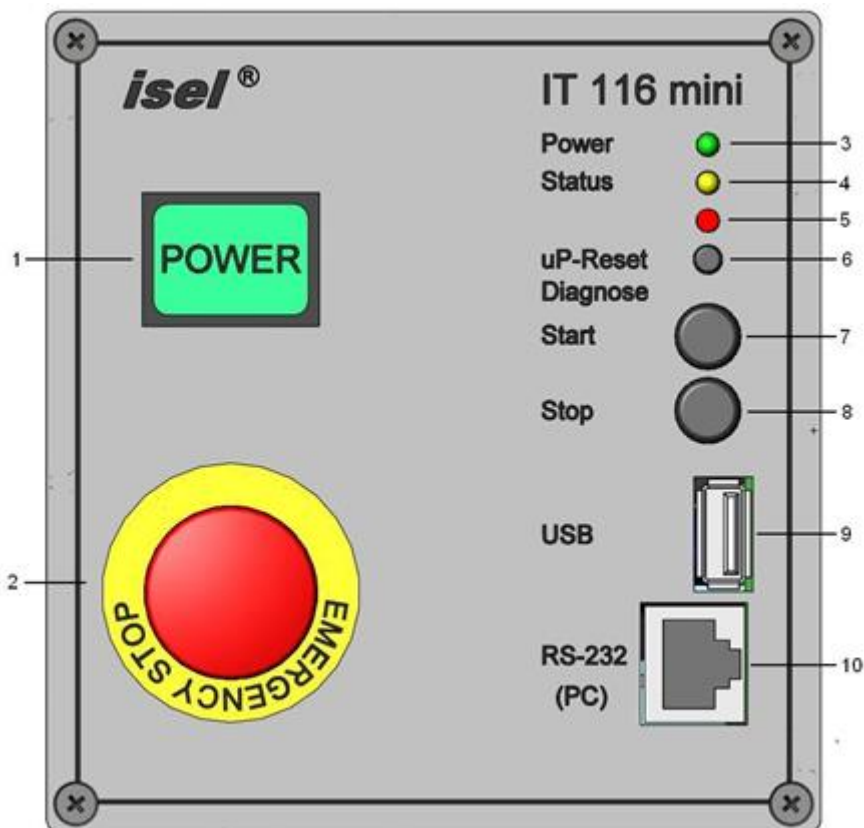

1 - Power-button

Use this button to switch on motor power supply voltage for the motor power amplifiers.

Conditions for switch on:

- Main power switch on the controller back side is switched on
- Emergency stop button is pulled out



Be sure that the contacts for external emergency stop switch on the remote connector are bridged!

If power supply voltage is successfully switched on the power button is lighted green.

2 – Emergency stop button

Turns off the power supply for the motor power amplifiers and the working spindle in case of any danger. This means dangers for the user's health or machine safety.



If you push the emergency stop switch the motor power supply will be switched off immediately (stop category 0, EN 60204-1) and any axes motion will be stopped. The main power supply voltage of 115/230VAC lies still on the device, only the motor power supply voltage for the amplifiers is switched off.

3 - LED – power

This LED signalizes that the net power supply voltage is switched on by the main switch on the back side of the controller.

4 - LED – diagnosis (future extension)

In case of any fault a blink code will be shown.

5- LED – over temperature

This LED signalizes a over temperature of the motor power amplifier.



LED only available on IT116 mini!

6- Reset button

Use this button to reset the micro processor and the motor power amplifier. All activities will be interrupted and signal outputs are set to default state. Possible appeared step losses will be ignored!

7 - Start button

Press this button to execute a stored user program in the flash memory of the controller.

8 - Stop button

Use this button to stop a running user program / axis motion. Press the start button to continue the execution of the user program / axis motion.

9 - USB slot (future extension)

This interface is used to connect a USB flash drive download user programs in the flash memory of the controller.

10 - RS232 programming interface

Communication between IT116 and control PC is realized via a serial interface (RS232). Use the delivered communication cable for connection. Plug the Sub-D (9-pin) connector to a COM port on the PC and the RJ45 connector to the controller front side socket.

A software protocol realizes the faultless transmission of the ASCII characters. Therefore it's necessary that both systems respect the communication protocol:

- The connected control PC sends a command which ends with a line end character [CR, char(13)].
- The processor unit quits the execution or storing of a command with the quitting signal 0[char(48)] or returns an occurred error with an ASCII character unequal 0.

Data transfer parameters on IT116 are defined as follows:

- 19200 baud, 8 data bits, 1 stop bit, no parity

4.2 Back side IT116 mini / IT116 flash

IT116 flash

IT116 mini

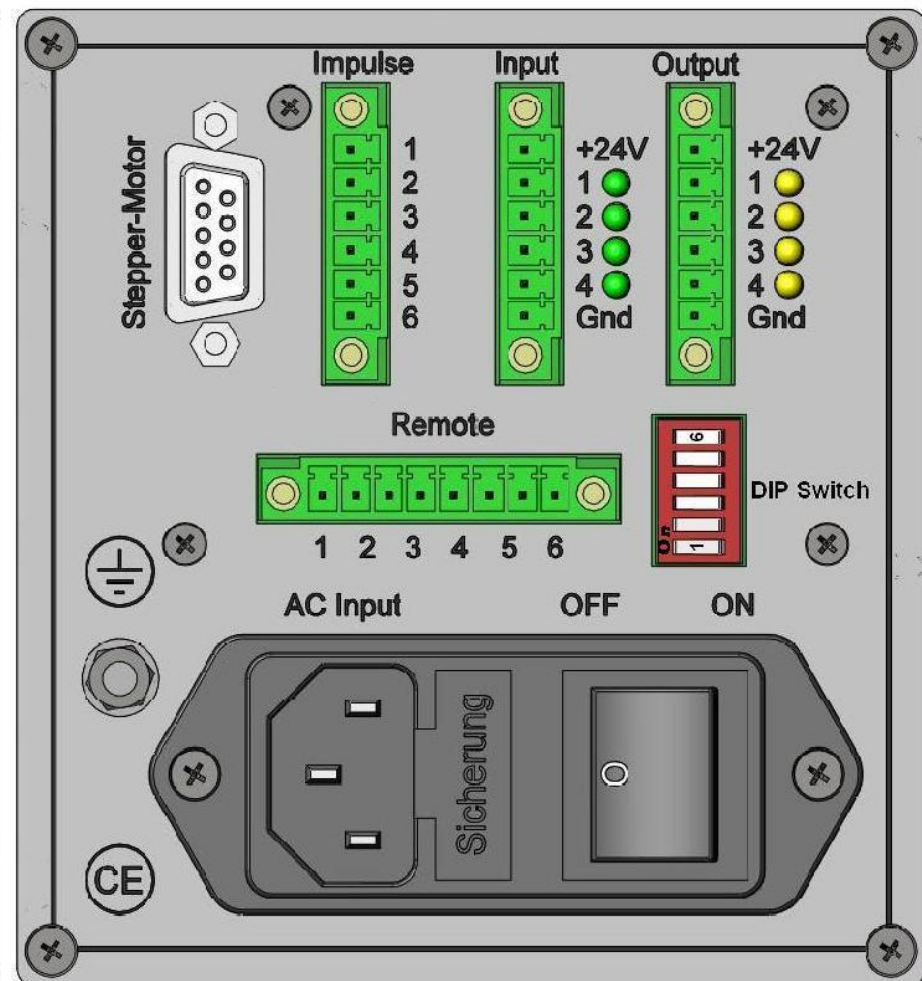
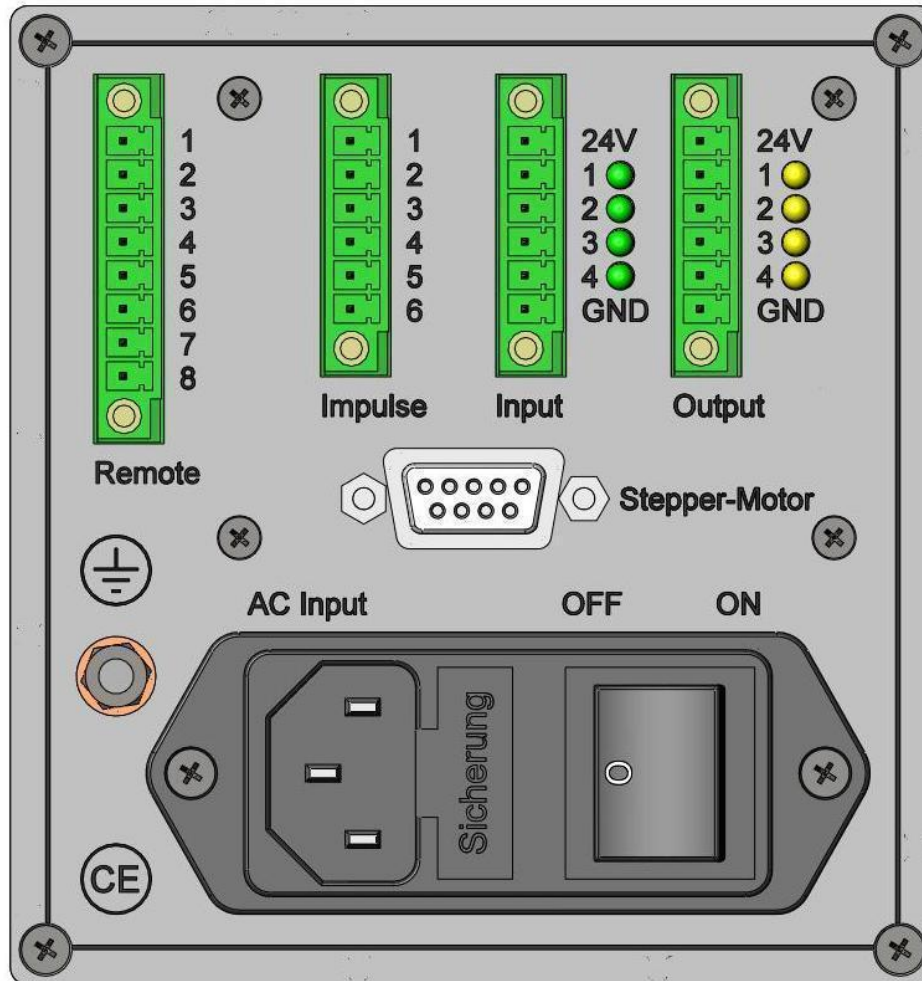

AC input – main net input module

The net input module consists of net input socket, net filter, fuse holder und net main switch. Connect the controller via delivered net cable to a free receptacle. After that you can switch on the controller with the net main switch.

Stepper-motor – connector

Sub-D 9-pin connector for motor module (CNC axis).



Connect / disconnect the Sub-D plug only if controller is switched off. dieses Ignoring this instruction can lead to damage the motor cable or stepper motor amplifier.

pin	description
1	motor phase 2B
2	motor phase 2A
3	motor phase 1B
4	motor phase 1A
5	+24VDC
6	brake (+24VDC/max. 0.8A output with reference potential GND)
7	limit switch 2 (Input → +24VDC, if limit switch 2 is not actuated: NC)
8	GND
9	limit switch 1 (Input → +24VDC, if limit switch 1 is not actuated: NC)

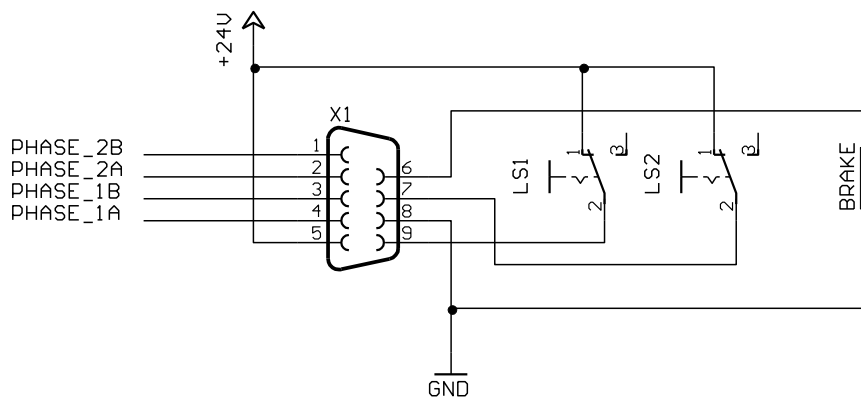

figure 1– motor module connector 2- phase stepper motor

Remote - interface to security circuit

This connector is used to integrate the controller into a higher ranked security circuit system. Please note that the external power button input is only useable if the power button in the front side of the controller is switched off. That will be realized by setting a jumper on the control board. Therefore you have to unscrew to front cover of the controller (look at figure 3, 4)

pin	description
1	potential free contact (make contact)
2	potential free contact (make contact)
3	external emergency stop (brake contact 1), 11
4	external emergency stop (brake contact 1), 12
5	external emergency stop (brake contact 2), 21
6	external emergency stop (brake contact 2), 22
7	external power (make contact)
8	external power (make contact)

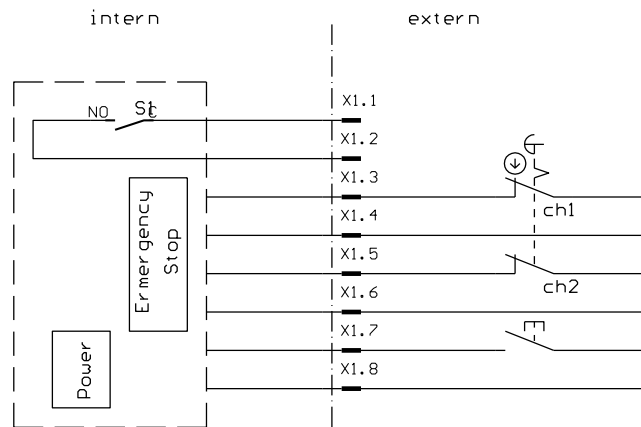

figure 2 – connection for external security circuit



The length of the connection cable for the external emergency stop button must not more than 5m.

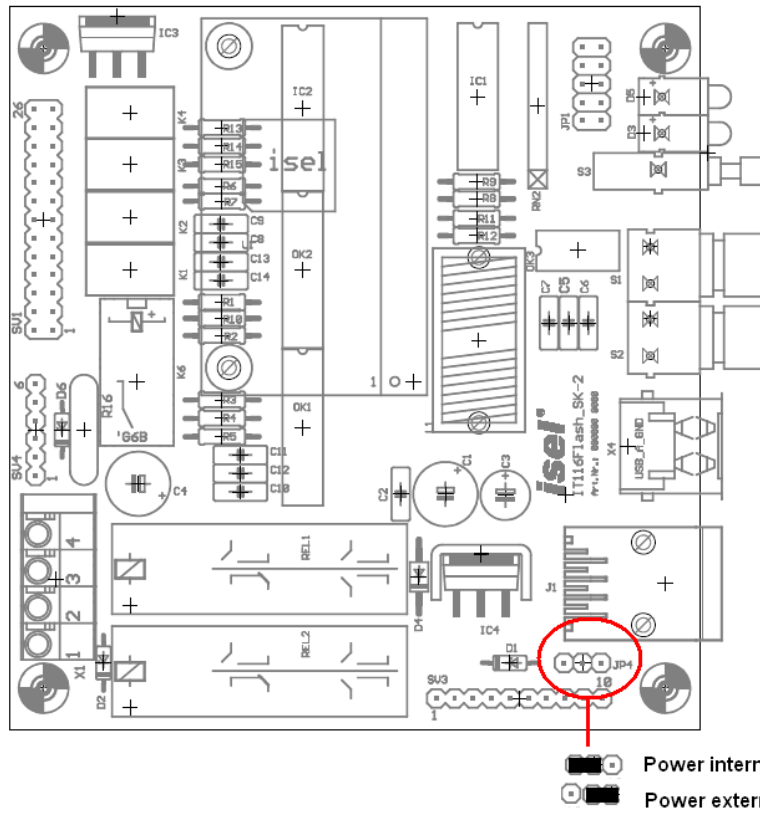

figure 3 – IT116 flash, jumper JP4 for power extern / intern

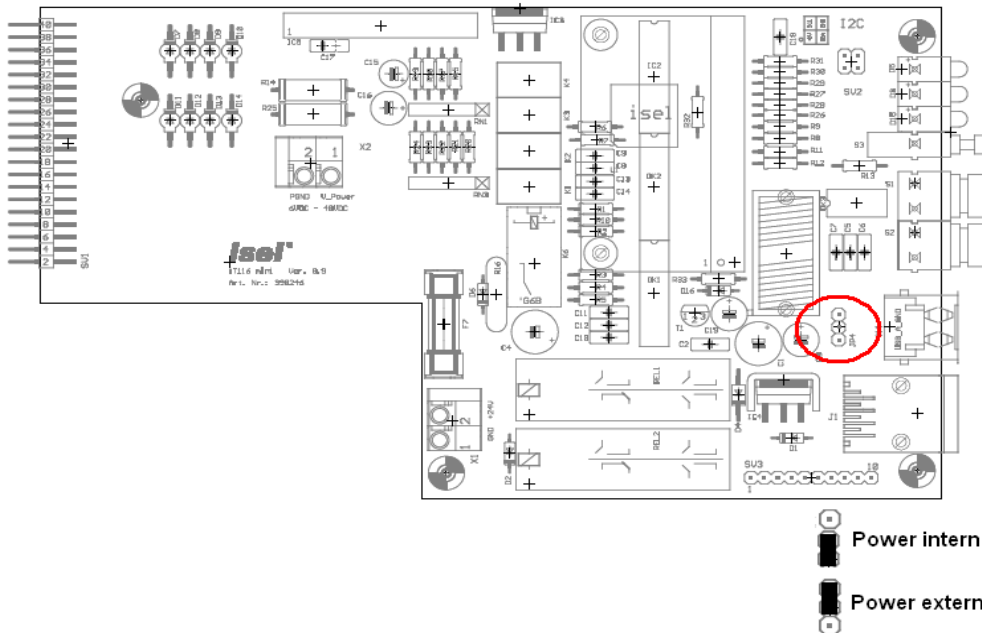

figure 4 – IT116 mini, jumper JP4 for power extern / intern

Impulse - interface impulse control

Use this connector to integrate the function keys start button, stop button and reset from the controller front side as external signal inputs.

pin	description
1	start
2	+24VDC
3	stop
4	+24VDC
5	reset
6	+24VDC

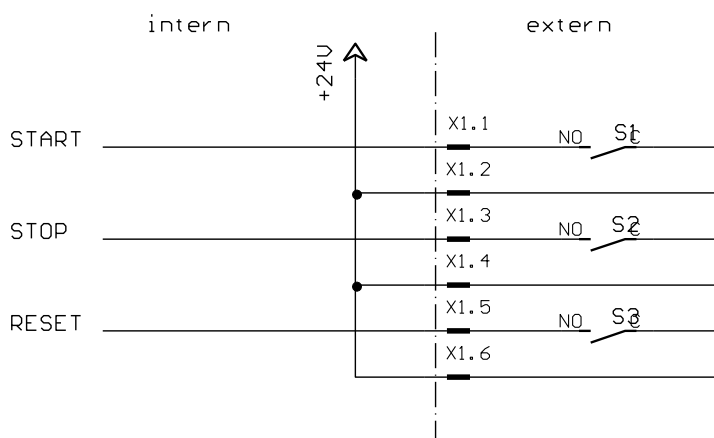

figure 5 – impulse control connection

Input - digital inputs

The controller IT116 flash / IT116 mini has 4 digital user inputs. Use these inputs to connect external devices like sensors, switches or outputs from other devices. All inputs are opto-decoupled. If +24VDC lies on the input a logical HIGH is signaled. Not connected (e.g. switch open) a logical LOW is signaled.

The input current is about 8 mA.

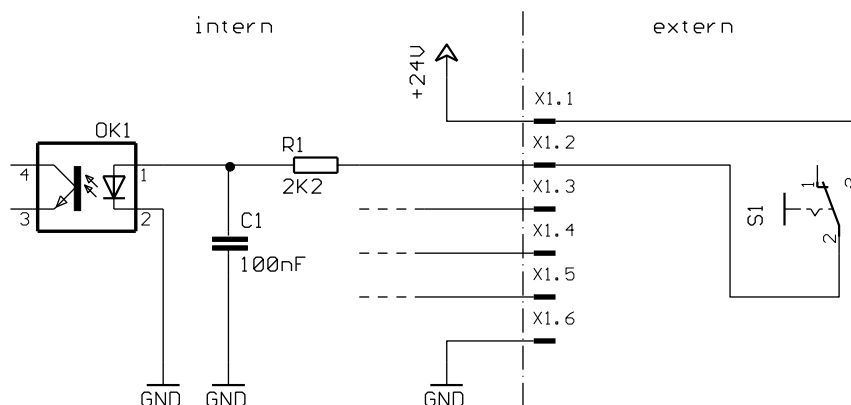

figure 6 – digital inputs wiring

Output - digital outputs

The controller IT116 flash / IT116 mini has 4 digital user outputs. Use these outputs to connect external devices like relays, or inputs from other devices. The maximum load of each relay output is 24 VDC/1 A.

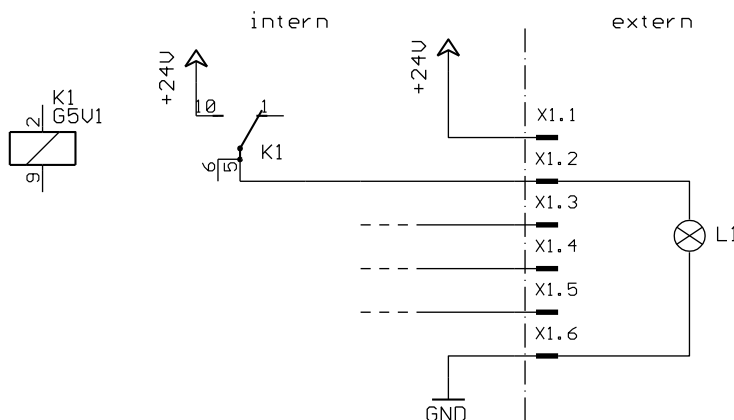

figure 7 – digital outputs wiring

4.3 DIP - switch settings

The DIP-switches are used to configure the motor amplifier. Depending on controller type the DIP switch is based on the top side (IT116 flash) or on the back side (IT116 mini) of the controller.



Configuration of the controller should be done before first startup so that a connected motor will not be damaged because of an incorrect power setting.

IT116 flash

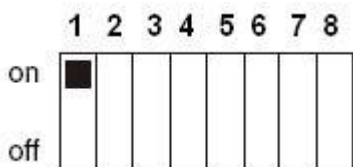

IT116 mini

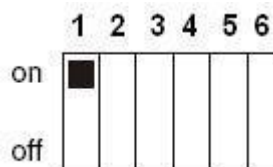

DIP switch is based on the **top side** of the controller.



DIP switch is based on the **back side** of the controller.

- 1: current setting 1
- 2: current setting 2
- 3: current setting 3
- 4: current reduction
- 5: step resolution 1
- 6: step resolution 2
- 7: step resolution 3
- 8: step resolution 4

- 1: switch motor brake „manually“
- 2: current reduction
- 3: step resolution 1
- 4: step resolution 2
- 5: current setting 1
- 6: current setting 2

4.3.1 DIP-switch settings on IT116 flash

current setting (DIP-switch 1, 2, 3)

Use the DIP switches 1, 2 and 3 to set the current of the motor. The following table shows the motor current (RMS) setting for the different switch positions:

Peak current (A)	RMS (A)	SW1	SW2	SW3
1	0,71	ON	ON	ON
1,46	1,04	OFF	ON	ON
1,91	1,36	ON	OFF	ON
2,37	1,69	OFF	OFF	ON
2,84	2,03	ON	ON	OFF
3,31	2,36	OFF	ON	OFF
3,76		OFF	OFF	OFF
4,2	3	OFF	OFF	OFF

not available



current reduction (DIP-switch 4)

Use the DIP switch 4 to set the automatic current reduction. If the DIP switch is set to ON the automatic current reduction is deactivated. DIP switch in state OFF means that the current is set to 60% of the motor current if the motor standstill.

DIP 4	current reduction in %
ON	0% reduction (deactivated)
OFF	60% reduction



If the holding torque is sufficient, the activated automatic current reduction is recommended.

step resolution (DIP-switch 5, 6, 7, 8)

Use the DIP switches 5, 6, 7 and 8 to set the step resolution. Setting the factor to a higher value causes a smooth motion of the motor but the maximum reachable velocity will taking down. Also the motor torque will be reduced to 75% in microstep mode. The following table shows the DIP switch settings for the different step resolutions:

micro steps	steps/ rev. (1,8 ° motor)	SW5	SW6	SW7	SW8
2	400	OFF	ON	ON	ON
4	800	ON	OFF	ON	ON
8	1600	OFF	OFF	ON	ON
16	3200	ON	ON	OFF	ON
32	6400	OFF	ON	OFF	ON
64	12800	ON	OFF	OFF	ON
128	25600	OFF	OFF	OFF	ON
5	1000	ON	ON	ON	OFF
10	2000	OFF	ON	ON	OFF
20	4000	ON	OFF	ON	OFF
25	5000	OFF	OFF	ON	OFF
40	8000	ON	ON	OFF	OFF
50	10000	OFF	ON	OFF	OFF
100	20000	ON	OFF	OFF	OFF
125	25000	OFF	OFF	OFF	OFF



The Factory set of the step resolution is 800 steps/rev for all motor power amplifiers.

4.3.2 DIP switch settings on IT116 flash 381017 SDZ6185

Current setting

The motor end stage is suitable for a maximum output current of up to 4.0A. Before the initial commissioning, set the peak current to the prescribed motor phase current. The setting is implemented via the integrated potentiometer, directly at the motor end stage. For this purpose, activate the control unit and supply it with mains voltage. Subsequently, remove the white cover cap on the M23 coupling for the motor connection. Below, the DIP switch for current reduction (must be switched off for setting) as well as the potentiometer and the test terminals for setting the reference voltage are located. Here, the output current corresponds to the measured reference voltage on the test terminals. By adjusting the potentiometer, the reference voltage on the test terminals and thus the output current change proportionally.

Example:

Measured reference voltage	Corresponds to output current
1.5V	1.5A
2.7V	2.7A
3.4V	3.4A

Current reduction (DIP switch 1)

Since the dwell moment of step motors is greater than the torque, via a current reduction, a dwell moment of a similar value than the torque can be achieved. The automatic current reduction at a motor standstill can be set via DIP switch 1. If DIP switch 1 is ON, the automatic current reduction is activated to 30% of the phase current.

Close the cover cap after having successfully set the motor current and current reduction.

Step resolution (factory-set)

A resolution of 800 steps per revolution is factory-set. By setting a greater factor for movement, a calmer run is achieved. However, the maximum achievable speed declines. Similarly, in microstep operation, the torque is reduced to approx. 75 %. Every change in the step resolution may only be implemented by isel Germany GmbH. In this respect, please contact our customer service.

4.3.3 DIP-switch settings on IT116 mini

switch motor brake „manually“ (DIP-switch 1)

Use this function to switch the motor brake manually. It can be necessary if you wish to move the motor with a hand wheel if main power supply voltage is switched off. In normal mode the DIP switch should be set to OFF.

DIP 1	brake
ON	output brake is always switched on
OFF	output brake will be switched automatically

current reduction (DIP-switch 2)

Use the DIP switch 2 to set the automatic current reduction. If the DIP switch is set to ON the automatic current reduction is deactivated. DIP switch in state OFF means that the current is set to 50% of the motor current if the motor standstill.

DIP 4	current reduction in %
ON	0% reduction (deactivated)
OFF	50% reduction



If the holding torque is sufficient, the activated automatic

step resolution (DIP-switch 3,4)

Use the DIP switches 3 and 4 to set the step resolution. Setting the factor to a higher value causes a smooth motion of the motor but the maximum reachable velocity will be taking down. Also the motor torque will be reduced to 75% in microstep mode. The following table shows the DIP switch settings for the different step resolutions:

micro steps	steps/rev (for 1,8° motor)	max. velocity in kHz	DIP 3	DIP 4
1	200	15 KHz	ON	ON
2	400	7,5 KHz	OFF	ON
4	800	3,75 KHz	ON	OFF
8	1600	1,875 KHz	OFF	OFF

current setting (DIP-switch 5,6)

Use the DIP switches 5 and 6 to set the current for the motor. It is possible to set the current in four steps:

current in A	DIP 5	DIP 6
3,33 A	ON	ON
2,50 A	OFF	ON
1,67 A	ON	OFF
0,67 A	OFF	OFF

5 Electrical connection and initial operation

Preparation

Before first startup of the controller please check the scope of delivery. The following parts should be included:

- Net power supply cable
- Null modem cable Sub-D 9-pin \leftrightarrow RJ45
- Package with connectors
- Operating instruction

If all this parts are included you can begin initial operation.

Provide all electrical connections.

Connectors

- Connect Net power supply cable
- Connect axis (motor) with the controller IT116 (back side)

configuration

- Set DIP-switches (see chapter 4.3)

Initial operation

- Switch on controller with main power switch on the back side
- Check if power LED lights
- Check if emergency switch is pulled out
- Push power button on the front of the controller
- If a user program is saved on the controllers flash memory you can press the start button to execute the program
- If no user program is saved in the flash memory you have to download your program from PC to controller (future extension – loading a user program from an USB flash device)
- Now it should be able to start execution of the program by pressing the start button
- If you have not written a user program you should be write your first user program with help of the software PALPC 2.1

6 PALPC: User programming for CNC mode and download

Creating user programs for 1-axis-controller IT116 flash /IT116 mini is realized with the software PALPC.exe. The implementation method is simple and described in /3/.

Analyze technological problem definition:

- Layout program algorithm (solve problem definition)
- Implementation of the control algorithm into a PALPC source program *.ppc; edit code with text editor
- Compile PALPC source file with PALPC compiler; on faultless translation an output file *.out is created by the compiler
- Download output file *.out into the flash memory of 1-axis-controller MC1
- Start program and check control behavior regarding technological problem definition

6.1 Install programming software PALPC.exe

To install PALPC software do the following:

1. Insert PALPC 2.1 (Part.-No.: Z11-331810) installation CD in your PCs / Notebooks CD/DVD drive. The following window will be shown.



2. Click on “Install PAL PC” and follow the installation instructions.



If this window is not shown start Windows Explorer and open the root directory of the CD/DVD drive / installation medium and double click on file “Autorun.exe”.

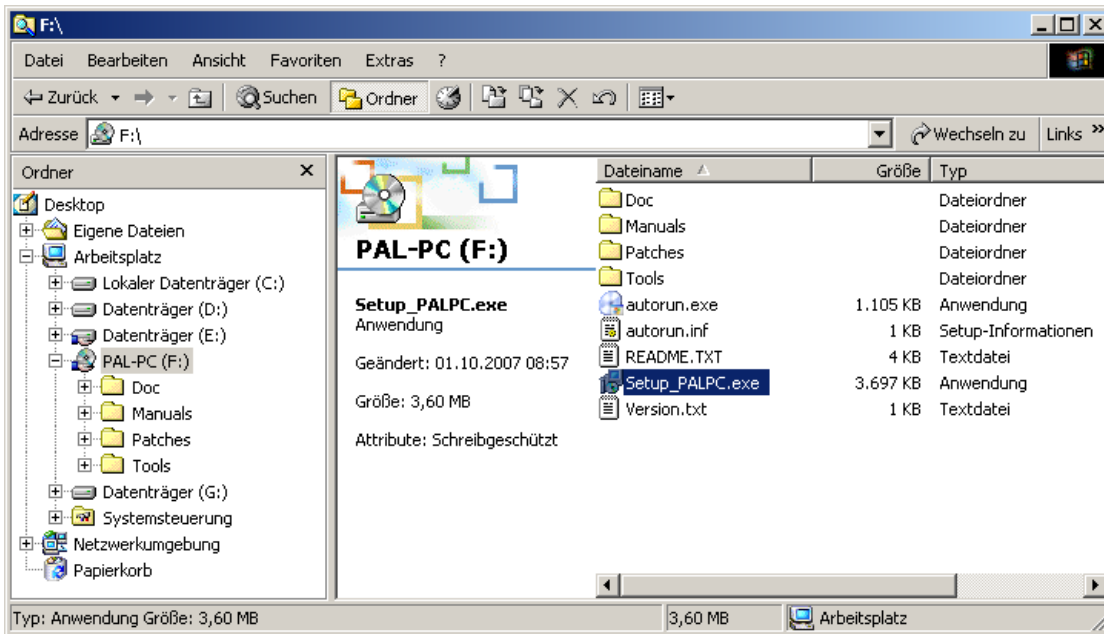

PALPC installation assistant → installation dialog:



3. Start PALPC.exe via start menu entry or desktop shortcut. On first startup an activation window will be shown. Enter delivered registration data (serial number and activation code) into the dialogs edit fields.

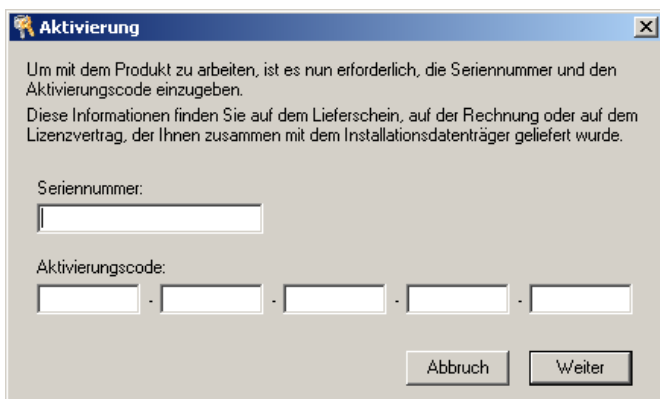

6.2 User programming for CNC mode and download

The use of PALPC and user programming are described in /3/.

For 1-axis-controller IT116 flash / IT116 mini note following specialties:

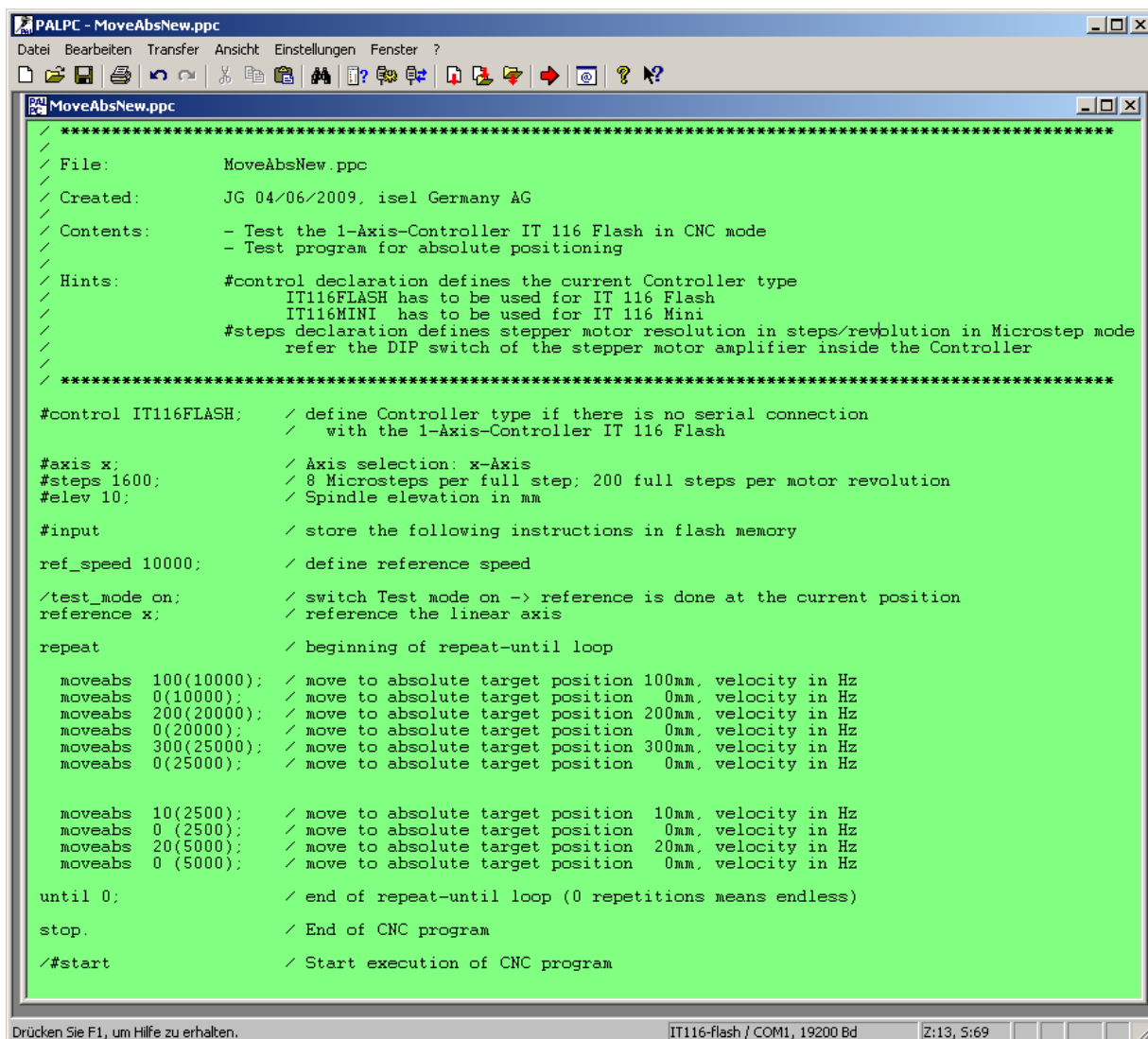

1. The declaration

#control IT116FLASH;
defines target controller as 1-axis-controller IT116 flash

#control IT116MINI;
defines target controller as 1-axis-controller IT116 mini

2. The declaration

#steps steps_ resolution ;
defines the step resolution set by DIP switch
e.g. *#steps 1600; /8* micro steps per full step * 200 full steps/motor revolution

3. The declaration

#elev value_spindle_elevation;
defines the spindle elevation of the connected linear axis,
e.g. *#elev 10* /elevation 10mm

#elev 360°/ transmission ratio;
defines the transmission ratio of the connected rotary axis,

e.g. ZR20 with transmission ratio 1:20:

$$\frac{360^\circ}{20} = 18 \rightarrow \text{\#elev 18;}$$

7 EG-Konformitätserklärung

EC - Declaration of Conformity



Der Hersteller

The manufacturer

isel Germany GmbH
Bürgermeister-Ebert-Str. 40
D-36124 Eichenzell

erklärt hiermit, dass folgendes Produkt

hereby declares that the following product

Geräteart: 1-Achs-Controller IT116
Device: 1-axis controller IT116
Typ: IT116 flash
IT116 mini
Type:
Art.-Nr.: 381016 | 381017 | 381017 SDZ6185
Product - No.:

mit den Vorschriften folgender Europäischer Richtlinien übereinstimmt:

complies with the requirements of the European Directives:

EG-Richtlinie 2014/30/EU

EC-Directive 2014/30/EC

EMV Richtlinie

EMC directive

EG-Richtlinie 2014/35/EU

EC-Directive 2014/35/EC

Niederspannungsrichtlinie

low voltage directive

EG-Richtlinie 2011/65/EU + 2015/863/EU

EC-Directive 2011/65/EC + 2015/863/EC

RoHS Richtlinie + delegierte Richtlinie

RoHS directive + delegated directive

Folgende harmonisierte Normen wurden angewandt:

Following harmonized standards have been applied:

- | | |
|--------------------|---|
| EN 61000-6-2:2006 | EMV - Fachgrundnorm - Störfestigkeit für Industriebereich
<i>EMC - Generic standards - Immunity for industrial environments</i>
<i>EMC - Testing and measurement techniques - Surge immunity test</i> |
| EN 61000-4-11:2005 | EMV - Prüf- und Messverfahren - Prüfung der Störfestigkeit gegen Spannungseinbrüche / Spannungsunterbrechungen
<i>EMC - Testing and measurement techniques - Voltage dips, short interruptions and voltage variations immunity tests</i> |
| EN 61000-6-4:2011 | EMV - Fachgrundnorm - Störaussendung Industriebereich
<i>EMC - Generic standards - Emission standard for industrial environments</i> |
| DIN EN 55011:2011 | Industrielle, wissenschaftliche und medizinische Hochfrequenzgeräte (ISM-Geräte) - Funkstörungen - Grenzwerte und Messverfahren
<i>Industrial scientific and medical (ISM) radio-frequency equipment - Electromagnetic disturbance characteristics - Limits and methods of measurement</i> |
| EN 60204-1:2006 | Sicherheit von Maschinen – Elektrische Ausrüstung von Maschinen – Teil 1: Allgemeine Anforderungen
<i>Safety of machinery – Electrical equipment of machines – Part 1: General requirements</i> |

Dernbach, 18.07.2019

Werner Kister, Vorstand / managing board

8 Bibliography

/1/ PAL-PC 2.0 programming instruction, 06/2004

/2/ MD24 / MD28 Microstepping Driver, Hardware Description, 02/2009

Operating instructions and manuals for download you can find here:

<https://www.isel.com/service/download>

9 Index

#

#control · 24
#elev · 24
#steps · 24

A

activation code · 23
air circulation · 5
Ambient temperature · 5

C

current reduction · 16
Current reduction · 18
current setting · 16

D

digital inputs · 7, 14
digital outputs · 7
digital outputs · 15
DIP –switch · 15

E

EG-Konformitätserklärung · 25

F

fuse · 7

H

harmonisierte Normen · 25

I

impulse control · 14
initial operation · 20
Initial operation · 20
installation dialog · 22
intended use · 5
IT116 flash · 6
IT116 mini · 6

L

Low voltage directive · 5

M

motor brake · 19
motor connector · 11

O

output file · 21

P

PALPC compiler · 21
PALPC.exe · 21
peak current · 7
power supply · 7
program memory · 7

R

rated current · 7
RS232 programming interface · 9

S

safety class · 7
Scope of delivery · 6
security circuit · 12
serial number · 23
step resolution · 17
Step resolution · 18
Storage temperature · 5

T

text editor · 21

W

weight · 7