



# CNC Servo Controller

**iCU-DC**  
**iCU-EC**

## Operating Instructions

The information, technical data and measurements in these printed materials conform to the latest technological advances at the time of publication. However, the possibility of printing errors and mistakes cannot be excluded. We would be grateful if you suggest improvements or point out errors.

We note that the software and hardware brand names used in our printed materials are generally subject to trademark, brand name or patent protection belonging to each respective company.

All rights reserved. No part of our printed materials may be reproduced in any form (print, photocopy or any other process) or processed, duplicated or disseminated via electronic systems without written permission from **isel Germany GmbH**.

Manufacturer: **isel Germany GmbH**  
Bürgermeister-Ebert-Straße  
40 D-36124 Eichenzell

Tel.: +49 (0)6659 981-0  
Fax: +49 (0)6659 981-776  
Email: [info@isel.com](mailto:info@isel.com)  
<https://www.isel.com>

Revisions	Date of change	Reason for change	Changed by
d	24/05/2023	Changing installation software	KJ
c	22/07/2019	Changing layout, adaption RoHS	KJ
b	04/07/2018	Page 15 changed, E/A ports	CB
a	05/01/2015	Serial number	RL
	2014	First print	

We reserve the right to make technical changes.  
Current operating instructions and manuals can be downloaded at:

<https://www.isel.com/service/download>

## Contents

<b>1</b>	<b>Introduction .....</b>	<b>4</b>
1.1	Safety symbols .....	4
1.2	Safety information .....	5
<b>2</b>	<b>Variants .....</b>	<b>7</b>
<b>3</b>	<b>Technical data .....</b>	<b>8</b>
<b>4</b>	<b>Hardware description.....</b>	<b>9</b>
4.1	Front side.....	9
4.2	Back side of iCU-DC / iCU-EC.....	11
4.3	Structure of iCU-DC / iCU-EC.....	19
<b>5</b>	<b>Initialisation .....</b>	<b>20</b>
<b>6</b>	<b>Software .....</b>	<b>21</b>
6.1	Installation of the initialisation software.....	21
6.2	Installing ProNC / Remote and first steps .....	23
<b>7</b>	<b>EC Declaration of Conformity .....</b>	<b>27</b>
<b>8</b>	<b>List of sources .....</b>	<b>28</b>
<b>9</b>	<b>Index.....</b>	<b>28</b>

## 1 Introduction

The CAN Controllers of the iCU Series are compact, high-performance drive controllers for 2 to 6 linear or rotational axles. The table housing integrates all control components required for solving various automation tasks.

The table housing integrates all control components required for solving widely varying automation tasks. These range from the output stage to the I/O component group to safety controlling.

The control computer interface is a CANopen PCI card which serves as a CAN master for the drive regulators and the I/O component group. External expansions for up to 128 CAN nodes are also easily possible. The connections on the back side of the control computer make it possible to easily connect a monitor, among other things. USB sockets are available for attaching various peripheral equipment such as mouse and keyboard. A LAN connection allows for integration into an existing network and can also be used for remote maintenance.

The NC controller core makes it possible to interpolate up to 6 axles (linear, circular, or helix), and online and Lock Ahead belt processing are also available. Using the software ProNC, individual axles can be controlled as handling axles (besides the interpolating axles).

The **iCU-DC** CAN Controllers can drive up to 6 brushed DC servo motors. The **iMD10** output stages in use have automatic jerk limitation and standstill monitoring (up to safety category 3).

Controllers in the **iCU-EC Series** can drive up to 6 brushless DC servo motors. The **iMD20** output stages in use have automatic jerk limitation and standstill monitoring (up to safety category 3).

### 1.1 Safety symbols

**Warning!**

Warning of dangers which can lead to adverse effects on health, physical injury, or death.

**Warning! Life-threatening voltage**

Warning of danger from electrical current. Non-compliance can result in severe injury or death.

**Attention!**

This symbol is for notices, non-observance of which can lead to damage or faults.

**Information:**

This symbol is for important information and notices.

## 1.2 Safety information



- The iCU-DC and iCU-EC CNC Controllers are constructed according to current technological advances and recognised safety regulations.
- The machine must only be operated when it is in perfect technical condition. Faults must be dealt with immediately. Children, and anyone who has not been trained, are not permitted to operate the machine.
- The machine must only be used according to its intended purpose. Control of 2 to 6 linear or rotational axles with brushed DC servo motors (iCU-DC) or brushless DC servo motors (iCU-EC) and incremental measurement system (encoder).
- All work must only be done by authorised specialist personnel with regard to the regulations of the electrical industry as well as accident prevention regulations. Before opening the housing or doing any work on the electrical installation, you must unplug the power cable.
- Assembly and use of equipment must be carried out according to the norms of the Declaration of Conformity. The regulations and threshold values observed by the manufacturer are not sufficient to protect from improper use of the equipment.
- The device must not be exposed to high air humidity or high levels of vibration.
- Keep this manual in a safe place and oblige each user to comply with it!
- Failure to observe these operating instructions can cause property damage, severe physical injuries, and death.

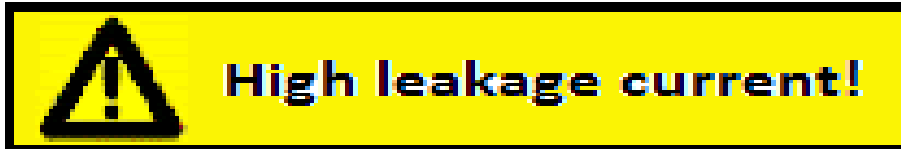

- **Warning! High earth leakage current (ground discharge current, protection conductor current).** Before connecting to the AC supply network, it is necessarily required an **additional protective grounding**. Before connecting the CNC controller to the AC supply network, an **additional protective grounding** (cross section: 2.5 mm<sup>2</sup> or 4 mm<sup>2</sup>, see below) has to be connected! Before the electrical start-up of the controllers a protective grounding of 2.5 mm<sup>2</sup> (protected installation) or a protective conductor of 4 mm<sup>2</sup> (unprotected installation) has to be connected durably to the marked clamping point  at the back of the housing where the cross section of the protective grounding shall not be less than 10 mm<sup>2</sup> copper or 16 mm<sup>2</sup> aluminum has (e.g. electrical distribution of the building). Please instruct an electrician with these implementation. When using the Residual Current circuit Device (RCD) for line fuses/fault current delimitation: Do not use an RCD with AC characteristics. Using a frequency inverter and choppered power stages in the power units may cause superimposed AC fault units with pulsating direct current and direct current apart from AC fault currents. Please consult your electrician.
- **The term leakage is understood here as grounding discharge current. This is defined in the standard EN 60204-1:2006 section 8.2.8, note 1**
- **If the CNC machine (ideal) is set up isolated from the reference potential, the grounding discharge current is equal to the protective grounding stream.**

## 2 Variants

Type	Motor	Output stages	max. Number of axles
<i>iCU-DC</i>	BDC Servo motors (brushed)	iMD10	6
<i>iCU-EC</i>	BLDC Servo motors (brushless)	iMD20	6

### Scope of delivery iCU-DC (Art.-No. 354002 10X<sup>10</sup>)

- iCU-DC servo controller as a tabletop device with the following components:
  - max. 6 integrated iMD10 performance output stages for brushed DC servo motors /1/
  - Control computer iPC25 with CAN PCI card iCC10
  - CAN IO 8/12-4/1 Module
  - Safety circuit module iSM5
- Power cable 230VAC (Safety contact plug, IEC-60320 appliance connector plug)
- RS232 communications cable for firmware updates, 9 pin sub-D (socket) to RJ45 (plug)
- Accessories kit (appliance plug connector, strapping plug, etc.)
- Remote control software **from Version 1.46.6.6** (optional: ProNC)
- Operating Instructions
- Optional: Frequency converter SKC750, SKC1500 for main spindle drive, **→ max. 4 axles possible**

### Scope of delivery iCU-EC (Art.-No. 354002 20X<sup>10</sup>)

- iCU-EC servo controller as a tabletop device with the following components:
  - max. 6 integrated iMD20 performance output stages for brushless DC servo motors /2/
  - Control computer iPC25 with CAN PCI card iCC10
  - CAN IO 8/12-4/1 Module
  - Safety circuit module iSM5
- Power cable 230VAC (Safety contact plug, IEC-60320 appliance connector plug)
- RS232 communications cable for firmware updates, 9 pole sub-D (socket) to RJ45 (plug)
- Accessories kit (appliance plug connector, strapping plug, etc.)
- Remote control software **from Version 1.46.6.6** (optional: ProNC)
- Operating Instructions
- Optional: Frequency converter SKC750, SKC1500 for main spindle drive, **→ max. 4 axles possible**

---

<sup>1</sup> X ... Number of axles, 2-6

### 3 Technical data

Controller	iCU-DC	iCU-EC
<i>Servo motor type</i>	BDC Servo motors (DC brushed)	BLDC Servo motors (DC brushless, EC)
<i>Max. Number of axles</i>	6	
<i>Power input</i>	115 - 230 VAC, 50 ... 60 Hz	
<i>Fuses</i>	2 x 6.3A (inert)	
<i>Power supply performance</i>	1000 W	
<i>Performance output stage</i>	iMD10	iMD20
<i>Intermediate circuit voltage</i>	48 VDC	
<i>Max. Nominal motor current</i>	12 A	
<i>Max. Peak motor current</i>	25 A	
<i>Descriptive code for safety data</i>	EN ISO 13849-1:2006 Category 3, PL d	
<i>Protection type</i>	IP20	
<i>Environment temperature</i>	0°C to 50°C	
<i>Storage temperature</i>	-20°C to +65°C	
<i>Air humidity</i>	max. 90%, non-condensating	
<i>Safety functions</i>	Can be integrated into higher-level emergency stop circuits, hood control, spindle control	
<i>I/O component group</i>	4 digital inputs 8 digital outputs (4 relay outputs, 4 electrical outputs) 1 x 115-230 V relay output (max. 6A)	
<i>Control computer</i>	1.8 GHz processor RAM ≥ 1 GB Hard drive 2.5" SATA ≥ 120 GB 2 x USB 2.0 on the front	
<i>Operation</i>	Function keys, emergency stop	
<i>Operating system</i>	Windows Embedded standard 7 (64Bit)	
<i>Control software</i>	Remote (Optional: ProNC, isyCAD/CAM)	
<i>Measurements, W x H x D</i>	630 x 230 x 400	630 x 230 x 400

## 4 Hardware description

### 4.1 Front side



#### 1 - Emergency stop switch

The emergency stop switch is for switching off the power supply to the stepping motor output stage in case of danger.

By this we are referring to dangers which could affect the health of the operator or the safety of the machine.



***When the emergency stop switch is activated, axle movement is braked in a controlled manner and the main voltage is switched off according to Stop Category 1 with a time delay (DIN EN 60204-1). The 115/230VAC power supply is still connected to the machine. Only the power supply to the output stage is switched off.***

#### 2 - Power button

Using the you can switch on the voltage supply to the output stages. The pre-requirements for this are:

- The power source must be switched on using the backwards “on” switch.
- The emergency stop switch must be “pulled out”.

When the main voltage is successfully switched on, this is signalled by the lighted power button.

#### 3 - Mode Selection Switch (Key switch)

This key switch selects Automatic or Setup mode.



*In **automatic mode**, you can **only open the machine's hood or door** when the **axles are not moving** and the connected **milling spindle is switched off**.*

*In **setup mode**, you can **only open the machine's hood or door** when the **working spindle is switched off**. In this mode **you can also drive the axles with the hood open, if you press the Acknowledge button "ACK" to do so**.*

***Ensure that only trained personnel are allowed operate the machine when it is in setup mode (key switch set to TEST)!***

#### **4 - Start button**

Pressing the Start button will open either the user program (ISO, PAL or NCP file) within the operating interface ProNC, or the user application (ISO, NCP or CNC file) within the remote control program.



*If no user program is open when you press the Start button, ProNC or Remote will request you to select a user program.*

#### **5 - Stop button**

Pressing the interrupts a running user program / axle movement. You can then resume the user program / axle movement by pressing the Start button.

#### **6 - Cover button**

This button is used to open the hood (if there is one). The hood can only be opened when the conditions are fulfilled as described under "Mode Selection Switch". The button will light up in white when the hood is released for opening.

#### **7 - Fault signal**

The fault signal shows that there is a fault in the safety circuit.

#### **8 - ACK (ACKnowledge button)**

You must press this button in order to move the axles in setup mode with the hood open.

#### **9 - PC Start button**

Press this button to switch on the integrated control computer.

#### **10 - USB 2.0 connections**

USB devices (data sticks, external CD/DVD drives) can be connected to these sockets.

**4.2 Back side of iCU-DC / iCU-EC**

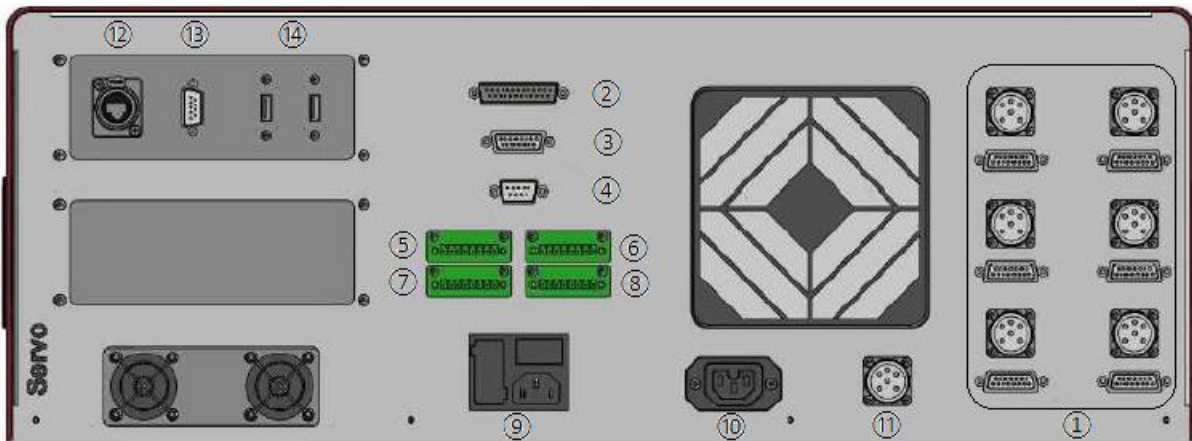

**① Connections for motor and encoder signal cables**

**iCU-DC - Motor, Encoder and Signal Cables**

*Motor connection (X, Y, Z, A, B, C), 8+1 pole M23 socket*

Pin	Signal	Wire number	Name
1	1	1	Motor phase 1*
2	2	2	Motor phase 2*
3	1	3	Motor phase 1*
4	2	4	Motor phase 2*
5	Brake	brown	Motor brake
6	Brake_GND	white	Motor brake GND
7	---		
8	---		
9	PE	yellow / green	grounding conductor

\* Each motor phase is connected via two wires.

*Encoder/ Signal connection, 15 pole Sub-D socket*

Pin	Signal	Cable wire colour	Name
1	n/a		
2	VCC_Encoder	red	Digital +5V DC
3	/ENC_Z	orange / black	Encoder track /Z
4	/ENC_B	brown / black	Encoder track /B
5	/ENC_A	Grey / black	Encoder track /A
6	VCC_Logic		Logic +24V DC
7	LIMIT_SW1		End position switch 1
8	GND_24V		Logic GND
9	n/a		
10	D_GND	black	Digital GND
11	ENC_Z	orange	Encoder track Z
12	ENC_B	brown	Encoder track B
13	ENC_A	grey	Encoder track A
14	REF_SW	green	Reference switch
15	LIMIT_SW2		End position switch 2

## **iCU-DC - Motor, Encoder and Signal Cables**

*Motor connection (X, Y, Z, A, B, C), 8+1 pole M23 socket*

<b>Pin</b>	<b>Signal</b>	<b>Cable wire colour</b>	<b>Name</b>
1	U	black 1	Motor phase U
2	V	black 2	Motor phase V
3	W	black 3	Motor phase W
4	---		
5	Brake	brown	Motor brake
6	Brake_GND	white	Motor brake GND
7	---		
8	---		
9	PE	yellow / green	grounding conductor

*Encoder/ Signal connection, 15 pole Sub-D socket*

<b>Pin</b>	<b>Signal</b>	<b>Cable wire colour</b>	<b>Name</b>
1	HALL_A_IN	yellow	Hall Signal A
2	VCC_Encoder	red	Digital +5V DC
3	/ENC_Z	orange / black	Encoder track /Z
4	/ENC_B	brown / black	Encoder track /B
5	/ENC_A	Grey / black	Encoder track /A
6	VCC_Logic		Logic +24V DC
7	LIMIT_SW1		End position switch 1
8	GND_24V		Logic GND
9	HALL_B_IN	white	Hall Signal B
10	D_GND	black	Digital GND
11	ENC_Z	orange	Encoder track Z
12	ENC_B	brown	Encoder track B
13	ENC_A	grey	Encoder track A
14	HALL_C_IN	green	Hall Signal C
15	LIMIT_SW2		End position switch 2

② **Manual operating console** - 25 pole Sub-D (optional model)

This connection is only used for controllers that do not have the integrated function keys in the front of the housing.

This connects the operating elements (buttons, switches) of:

- an external manual operating console
- an Isel CNC operating panel

with the appropriate socket on the safety circuit module of the controller inside the controller housing.

Pin	Signal	Name
1	EMERGENCY STOP_1	Emergency Stop channel 1, connection 1.1
2	EMERGENCY STOP_1	Emergency Stop channel 1, connection 1.2
3	EMERGENCY STOP_2	Emergency Stop channel 2, connection 2.1
4	EMERGENCY STOP_2	Emergency Stop channel 2, connection 2.2
5	24V	+24 V DC
6	POWER BTN	Power button input
7	POWER LAMP	Power light output
8	24V	+24VDC
9	KEY SWITCH Test	Key switch test mode input
10	KEY SWITCH Auto	Key switch automatic mode input
11	24V	+24VDC
12	ACK_1	Acknowledge button channel 1 input
13	24V	+24VDC
14	ACK_2	Acknowledge button channel 2 input
15	COVER SWITCH	Cover button input
16	COVER SWITCH	Cover button output
17	GND	
18		
19		
20	FAULT LAMP	Fault light output for operating console
21	START BTN	Start button input (normally open contact)
22	STOP BTN	Stop button input (normally closed contact)
23	START LAMP	Start light output
24	STOP LAMP	Stop light output
25	n/a	



*The length of the connection cable for the manual operating console / CNC operating panel is max. 5m.*

③ **Additional operating console** - 15 pole Sub-D (optional model)

We use this connection when an additional Isel operating console is connected.

Pin	Signal	Name
1	EMERGENCY STOP_1	Emergency Stop channel 1, connection 1.1
2	EMERGENCY STOP_1	Emergency Stop channel 1, connection 1.2
3	EMERGENCY STOP_2	Emergency Stop channel 2, connection 2.1
4	EMERGENCY STOP_2	Emergency Stop channel 2, connection 2.2
5	GND	GND operating console
6	LAMP ACK	ACK light switch output
7	24V	+24VDC
8	ACK_1	Acknowledge button channel 1 input
9	24V	+24VDC
10	ACK_2	Acknowledge button channel 2 input
11	COVER SWITCH 1	Cover button input 1
12	COVER SWITCH 1	Cover button output 1
13	COVER SWITCH 2	Cover button input 2 (optional)
14	COVER SWITCH 2	Cover button output 2 (optional)
15	n/a	



*The length of the connection cable for the additional operating console is max. 5m.*

④ **Cover** - Sub-D 9 pole socket

At this connection, you can integrate the of the attached machine into the controller's safety circuit.

Pin	Name
1	+Coil, normally closed contact
2	Switch 1, 1.1
3	Switch 1, 1.2
4	Switch 2, 2.1
5	Switch 2, 2.2
6	-Coil, normally closed contact
7, 8, 9	not used

⑤ **Digital Inputs** - 8 pole, left to right E1.1 – E1.4

The installed I/O component group has one digital input port. The inputs E1.5 - E1.8) are already partially wired internally and occupied by signal inputs and not usable by the user. The digital inputs E1.1 - E1.4 may be assigned by the user.

**Properties**

- Optoelectronic coupler inputs
- Input current approx. 8mA

**Wiring**

Pin	Input	Name
1	In 1	Input E1.1
2	VCC	+24VDC
3	In 2	Input E1.2
4	VCC	+24VDC
5	In 3	Input E1.3
6	VCC	+24VDC
7	In 4	Input E1.4
8	VCC	+24VDC

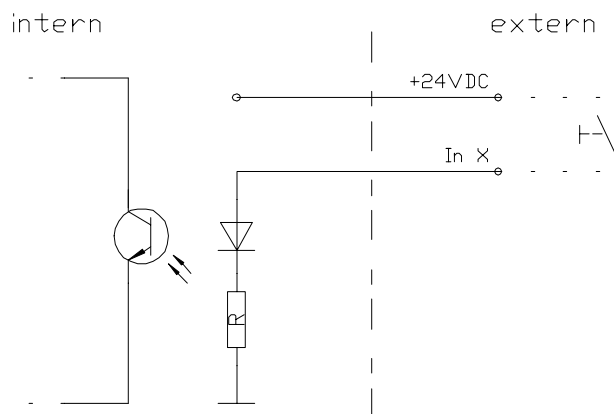

Note the default assignment of the first input port (E1.5 - E1.8) when setting the “signalling” in the user interface Remote / ProNC. **These inputs are already wired inside the controller to their modules and can no longer be used by the operator!**

⑥ **Remote-** Safety circuit interface, 8 pole, left to right

Using this interface, you can integrate the emergency stop circuit of the equipment output unit into a higher-level safety circuit system. Here you can also tap the analog output signal 0...10V of the integrated I/O module.

Pin	Signal	Name
1	EMERGENCY STOP_1	External emergency stop channel 1, connection 1.1
2	EMERGENCY STOP_1	External emergency stop channel 1, connection 1.2
3	EMERGENCY STOP_2	External emergency stop channel 2, connection 2.1
4	EMERGENCY STOP_2	External emergency stop channel 2, connection 2.2
5	ANA_GND	Analog GND
6	ANA_0_10V	Analog 0...10V DC
7	----	
8	----	

⑦ **Digital electrical outputs - 8 pole, left to right A1.1 – A1.4**

The installed I/O component group has two digital output ports, each with eight digital switching outputs. The first output port (A1.1 - A1.8) is already partially wired internally and occupied by switching outputs. The outputs A1.1 - A1.4 may be assigned by the user.

**Properties**

- 4 x digital electronic outputs
- I<sub>max</sub> < 350mA, 24VDC
- Thermal protection
- Short-circuit protection

**Wiring**

Pin	Output	Name
1	Out1	Output A1.1
2	GND	GND
3	Out2	Output A1.2
4	GND	GND
5	Out3	Output A1.3
6	GND	GND
7	Out4	Output A1.4
8	GND	GND

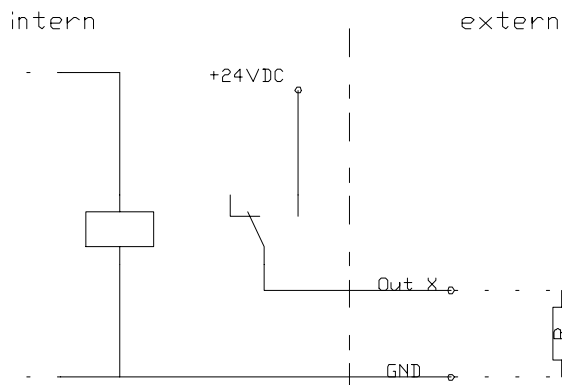

Note the default assignment of the first output port (A1.1 - A1.8) when setting the “signalling” in the user interface Remote / ProNC. **The outputs A1.5 - A1.8 are already wired inside the controller to their modules and can no longer be used by the operator!**



**When using inductance, a free-wheeling diode is necessarily.**

⑧ **Digital Relay Outputs - 8 pole, left to right A2.1 – A2.4**

The installed I/O component group has a second digital output port, with four more digital **relay switching outputs**. The second output port (A2.1 - A2.8) is already partially wired internally and occupied by switching outputs. The outputs A2.1 - A2.4 may be assigned by the user.

**Properties**

- 4 x digital relay outputs
- I<sub>max</sub> < 5 A, 24VDC
- Thermal protection
- Short-circuit protection

**Wiring**

Pin	Output	Name
1	Out1	Output A2.1
2	GND	GND
3	Out2	Output A2.2
4	GND	GND
5	Out3	Output A2.3
6	GND	GND
7	Out4	Output A2.4

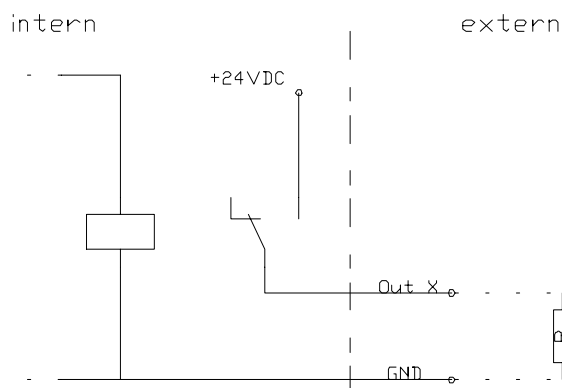
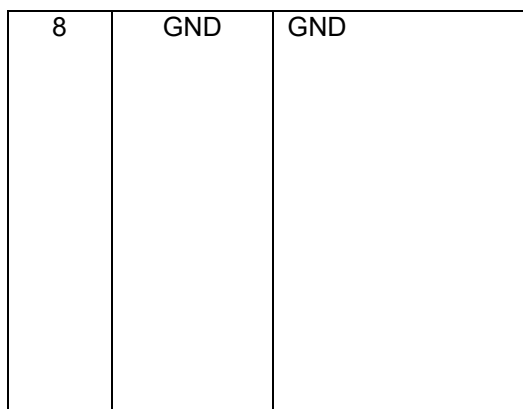

**⑨ AC Input – 115/230 VAC, 50 ...60 Hz**

The power input module includes these components: appliance connector socket, filter, fuse holder, fuses and power switch. The supplied power cable must be connected with the appliance connector socket and the power socket before initialisation. After that, the controller can be switched on using the main switch.



**! Neutral Conductor Fuse !**

**⑩ Spindle -115V/ 230V connection**

Here at this output, you can directly connect a milling spindle without RPM control if you use the supplied mating plug. Maximum switching at the relay output is 115V/230VAC / 6A. The signal for the spindle to start (output +24V) is switched via the CAN I/O module, analysed via the SK module (iSM5), and then the power supply of 115/230V is switched to the working spindle (e.g. UFM 500, 750, 1050) via a relay.



*Take note of the CAN I/O module table defining assigned spindle start signals, in section 4.2.*

**⑪ Connection for main spindle drive (optional)**

Here at this connection, a processing spindle with RPM control is attached (asynchronous motor). The (optional) frequency converter is located in the controller and is operated via the safety circuit and I/O module.

Pin	Name
1	Motor phase U
4	Motor phase V
3	Motor phase W
PE	PE
A	-
B	-
C	Fan 230V AC-L
D	Fan 230V AC-N
	Housing

**⑫ Ethernet connection for the integrated control computer, IPC15**

1x RJ45 socket for network integration (100MBit, LAN, Ethernet)

**⑬ VGA connection for the integrated control computer, IPC15**

15 pole connection socket for a VGA monitor

**⑭ USB 2.0 connections**

USB devices (data sticks, external CD/DVD drives) can be connected to these sockets.

4.3 Structure of iCU-DC / iCU-EC

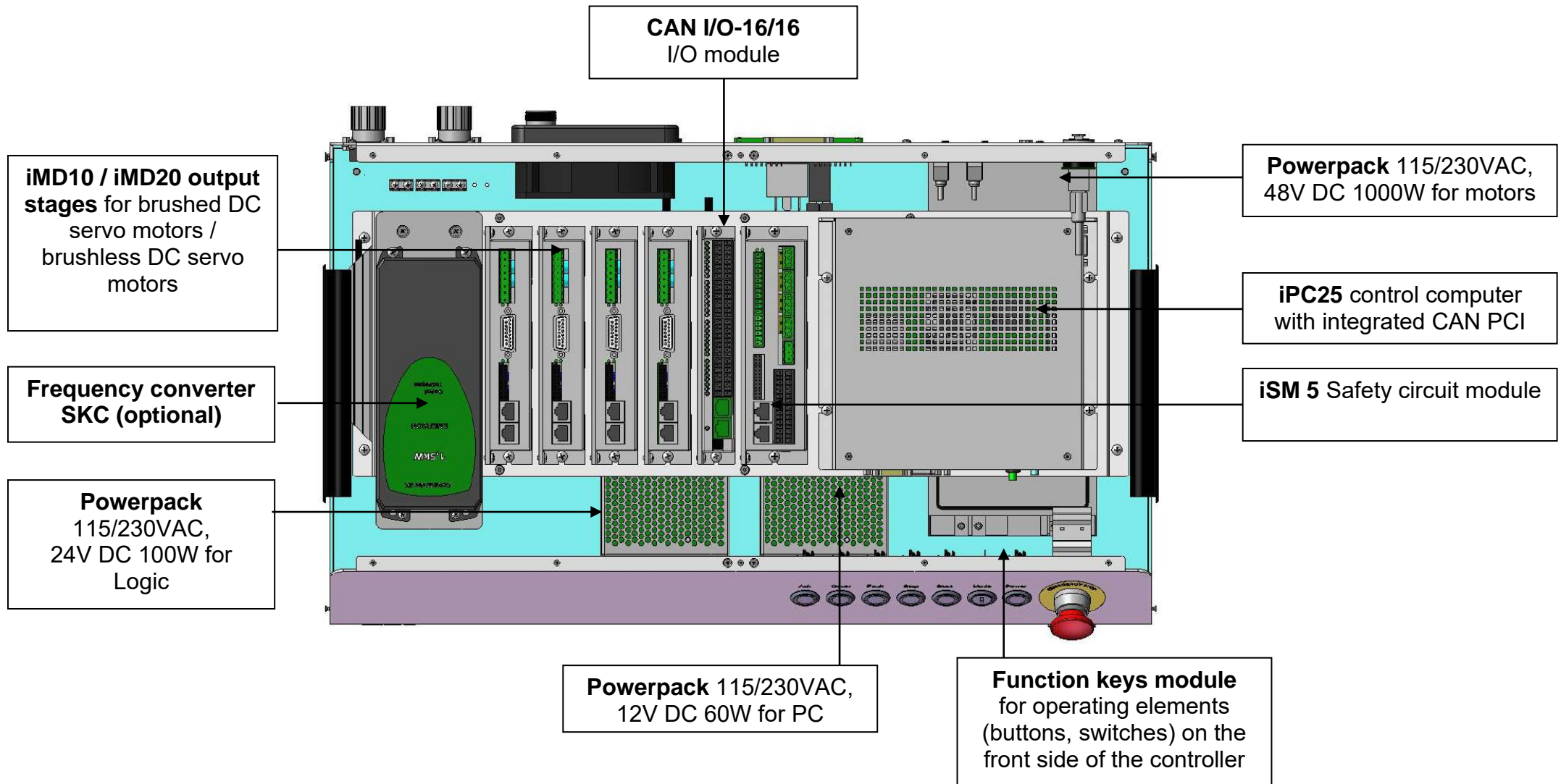

## 5 Initialisation

### Preparation

Before you first start up the controller, please check the scope of delivery. The following parts should be included:

- Power cable
- Operating Instructions

If all these are present, then you can begin with commi.



***If the environmental temperature is less than 0°C, you should leave the controller at room temperature for at least two hours before use, to prevent damage to the electronic components.***

To do this, first make all the necessary connections:

- Connect the power cable
- Connect the motor and encoder cables from the axles (motors) to the back of the controller
- Check that all the other cables are correctly attached to the controller

### Initialisation

- Use the power switch (on the back) to turn on the controller.
- Turn on the control computer using the green button on the back, this button should now light up in green → the computer will now boot up the installed operating system
- Installing the control software (if not already installed)
  - Remote or ProNC (1) **(from Version 1.46.6.6)**
- Installing the initialisation software (if not already installed)
  - DCSetup (2)
  - ACSetup (3)
- Check that the emergency stop switch is pulled out
- Press the power button - The power supply to the output stages should now be activated
- Parameterisation of the performance output stages using the program DCSetup.exe / ACSetup.exe
- Setting up the system's axle kinematics using CANSet.exe
- Operating the controller and the connected axles using the ProNC or Remote operating and programming interface

## 6 Software

### 6.1 Installation of the initialisation software

Initialisation / parameterisation of the motor output stages integrated in the controller's iCU-DC / iCU-EC is done using the initialisation programs

**DCSetup.exe (2)**

for:

***brushed DC servo motors with motor output stage IMD10***

or

**ACSetup.exe (3)**

for:

***brushless DC servo motors with motor output stage IMD20 and***

Please proceed as follows to install the initialisation programs after the fact:

1. Connect the ProNC/Remote installation medium (supplied USB stick) to the control computer.
2. Go to Windows Explorer, open the root directory of the installation media and double-click the autorun.exe file.



3. Click on the option “Install control software” and then the following window will appear on the screen:



Now choose the appropriate initialisation software for your motor type and click on the option (e.g. “[ACSetup installation](#)”) to begin the installation.

Follow the instructions in the installation wizard.

After installation is complete, click on “Finish” to close the auto-start menu.

Start the initialisation program **DCSetup.exe** / **ACSetup.exe** either via the shortcut on the Windows Desktop or via the start menu item:

Start → Programs ACSetup → DCSetup / ACSetup

*You can find information about the parameterisation of the iMD10 performance output stage in the handbook /1/ **DC servo positioning module with CanOpen Interface UVE 8112 / iMD10**. Open the file “dcsetup\_ger.pdf” using the start menu option.*



*You can find information about the parameterisation of the iMD20 and iMD40 performance output stages in the handbook /2/ **AC servo positioning module with CanOpen Interface iMD20 / iMD40**. Open the file “acsetup\_ger.pdf” using the start menu option.*

## 6.2 Installing ProNC / Remote and first steps

The **iCU-DC / iCU-EC** controller is operated either via the control software, Remote, or the programming software, ProNC.

If the factory has not installed any software yet, please proceed as follows to install the programs after the fact:

1. Connect the ProNC/Remote installation medium (supplied CD or USB stick) to the control computer.
2. The following auto-start window will appear (when installing from CD).



*If the auto-start window does not appear, please open Windows Explorer and open the main directory of the installation medium. Double-click on the file "Autorun.exe".*

3. Click on the option “**ProNC installation**”

Follow the instructions in the installation wizard.

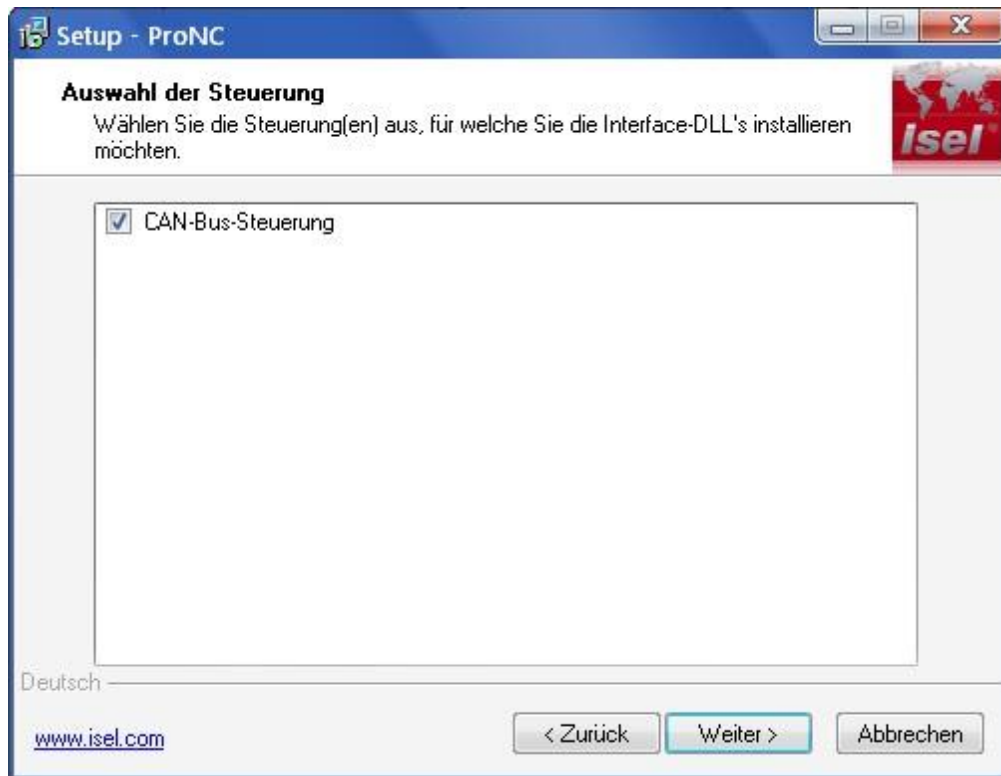

In the “Control Selection” window, select the item “CAN Bus Control” to install the CAN bus software module.

After installation is complete, click on “Finish” to close the auto-start menu.

4. Use the configuration program **CANSet.exe** (shortcut on the Windows Desktop or via the start menu option: Start → Programs → isel CAN CNC Control → CANSet), to set up machine-specific parameters (CAN interface, axles used, axle type, etc.).

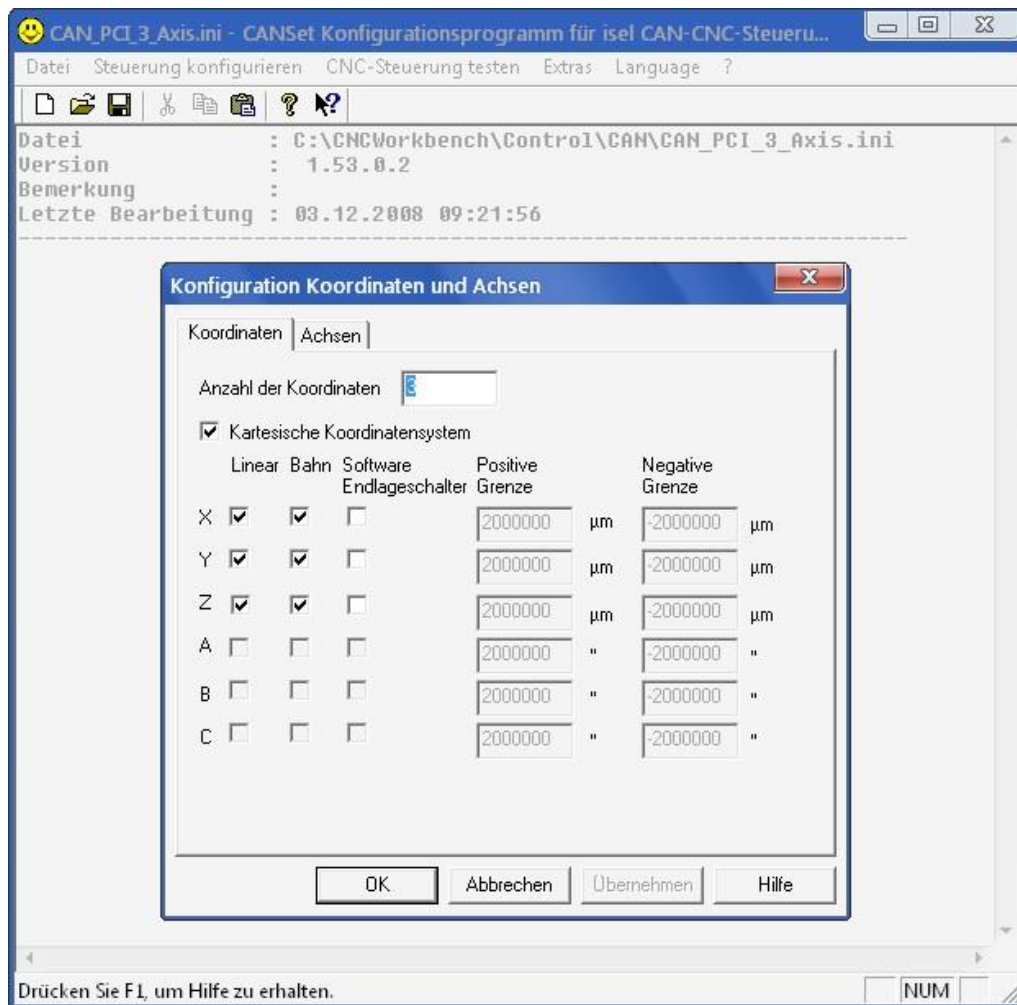

Save your configuration in an (\*.ini file). You must then later use this file in the ProNC/Remote operating interface as the motion control module DLL initialisation file.

5. Start the user interface ProNC.exe either via the shortcut on the Windows Desktop or via the start menu option:  
Start → Programs → CNC workbench → ProNC

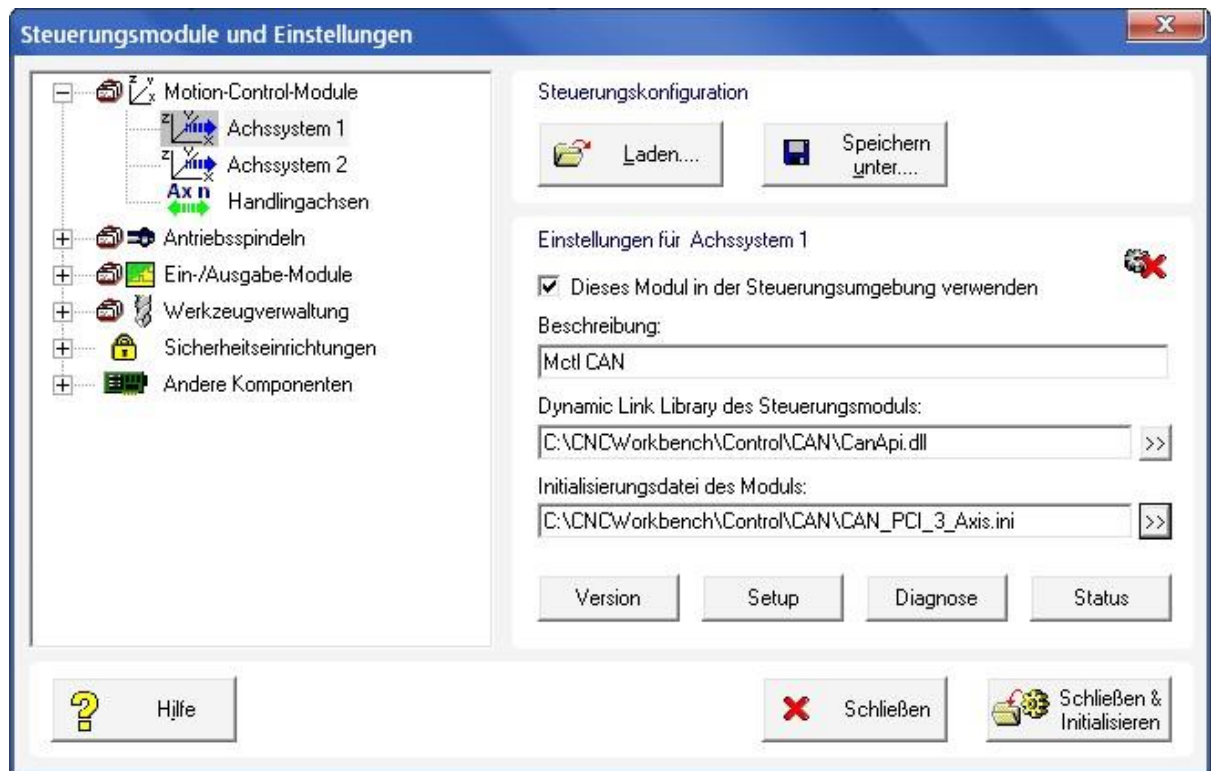

In the Settings menu (Menu→Settings→Control) for Motion Control Module → Axle system 1, select the initialisation file that you saved before. Click on the button “Save & Initialise” to save the settings and put the controls into their start settings.

6. Carry out a “Software Reset” and a “Reference Movement” to check the correct function of the machine and the system.



*For further information on configuring the ProNC / Remote, please refer to the programs’ online help sections (Help menu or F1 key).*

## 7 EC Declaration of Conformity

*The manufacturer*

**isel Germany AG**  
**Bürgermeister-Ebert-Str. 40**  
**D-36124 Eichenzell**

*hereby declares that the following product*

**Device:**           **CAN-Servo-Controller**

**Type:**             **iCU-DC / iCU-EC**

**Product No.:**   **iCU-DC:**               354002 10X0  
                          **iCU-EC:**               354002 20X0

*complies with the requirements of the European Directives:*

EG-Richtlinie 2014/30/EU <i>EC-Directive 2014/30/EC</i>	EMV Richtlinie <i>EMC directive</i>
EG-Richtlinie 2014/35/EU <i>EC-Directive 2014/35/EC</i>	Niederspannungsrichtlinie <i>low voltage directive</i>
EG-Richtlinie 2011/65/EU + 2015/863/EU <i>EC-Directive 2011/65/EC + 2015/863/EC</i>	RoHS Richtlinie + delegierte Richtlinie <i>RoHS directive + delegated directive</i>

*Following harmonized standards have been applied:*

EN 61000-6-2:2006	EMV - Fachgrundnorm - Störfestigkeit für Industriebereich <i>EMC - Generic standards - Immunity for industrial environments</i>
EN 61000-4-2:2008	EMV - Prüf- und Messverfahren - Prüfung der Störfestigkeit gegen Entladung statischer Elektrizität (ESD) <i>EMC - Testing and measurement techniques; Electrostatic discharge immunity test</i>
EN 61000-4-4:2012	EMV - Prüf- und Messverfahren - Prüfung der Störfestigkeit gegen schnelle transiente elektrische Störgrößen (Burst) <i>EMC - Testing and measurement techniques - Electrical fast transient/burst immunity test</i>
EN 61000-4-5:2007	EMV - Prüf- und Messverfahren - Prüfung der Störfestigkeit gegen energiereiche Impulse (Surge) <i>EMC - Testing and measurement techniques - Surge immunity test</i>
EN 61000-4-11:2005	EMV - Prüf- und Messverfahren - Prüfung der Störfestigkeit gegen Spannungseinbrüche / Spannungsunterbrechungen <i>EMC - Testing and measurement techniques - Voltage dips, short interruptions and voltage variations immunity tests</i>
EN 61000-6-4:2011	EMV - Fachgrundnorm - Störaussendung Industriebereich <i>EMC - Generic standards - Emission standard for industrial environments</i>
DIN EN 55011:2011	Industrielle, wissenschaftliche und medizinische Hochfrequenzgeräte (ISM-Geräte) - Funkstörungen - Grenzwerte und Messverfahren <i>Industrial scientific and medical (ISM) radio-frequency equipment - Electromagnetic disturbance characteristics - Limits and methods of measurement</i>
EN 60204-1:2006	Sicherheit von Maschinen – Elektrische Ausrüstung von Maschinen – Teil 1: Allgemeine Anforderungen <i>Safety of machinery – Electrical equipment of machines – Part 1: General requirements</i>

Dermbach, 18.07.2019

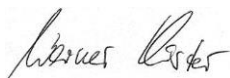

Werner Kister, Vorstand / managing board

## 8 List of sources

### /1/ isel Germany AG.

Positioning module with CanOpen Interface UVE8112 / iMD10. 03/2008.

### /2/ isel Germany AG.

Positioning module with CanOpen Interface iMD20 / iMD40. 03/2009.

### /3/ isel Germany AG.

ProNC Operating Instructions. 2003.

### /4/ isel Germany AG.

iPC25 Operating Instructions. 07/2014

Operating instructions and manuals can be downloaded at:

[www.isel-data.de/manuals](http://www.isel-data.de/manuals)

## 9 Index

		initialisation file	25
		initialisation software	21
		Installation	21
	<b>A</b>		
ACK	10		
ACSetup	20		
		<b>M</b>	
		<b>Mode Selection Switch</b>	9
		Motor connection	11, 12
BLDC Servo motors	7		
		<b>N</b>	
		Niederspannungsrichtlinie	27
CANSet.exe	20		
Cover button	10		
		<b>P</b>	
		power button	9
		Power input module	17
door lock	14	ProNC	20
		<b>R</b>	
		Remote	20
		<b>S</b>	
		Software	21
		Start button	10
		Stop button	10
	<b>I</b>		
iMD20	8		