



iselGermany
engineering to the point.

Linear guides

for mechanical engineering

Move safely and precisely



Automation sales team



Steffan Gärtch

Technical sales

Tel.: +49 (0) 6659 / 981-773

Fax: +49 (0) 6659 / 981-776

steffan.gaerth@isel.com



Katja Henkel

Technical sales

Tel.: +49 (0) 6659 / 981-744

Fax: +49 (0) 6659 / 981-776

katja.henkel@isel.com



Jessica Gatterdam

Team Assistant Sales

Tel.: +49 (0) 6659 / 981-751

Fax: +49 (0) 6659 / 981-776

jessica.gatterdam@isel.com

General Terms of Delivery and
terms of payment



www.isel.com/agb-aeb

Stand: Februar 2025



Content

Aluminum shaft slide.....	4
Load capacity and life-time.....	5
Linear guide rail type LFS-8-1 / LFS-8-2	6
Linear guide rail type LFS-8-3.....	8
Linear guide rail type LFS-8-4.....	10
Linear guide rail type LFS-8-7.....	12
Linear guide rail type LFS-12-1.....	14
Linear guide rail type LFS-12-11.....	16
Linear guide rail type LFS-12-2.....	18
Linear guide rail type LFS-12-3.....	20
Linear guide rail type LFS-12-10.....	22
T-slot accessories	24
Profile rail guide type PSF 15, 20, 25 and 30.....	26



The proper guide for every machine

High rigidity, load capacity for dynamic traversing and positioning movements, long-term accuracy and low-noise operation: The modern isel linear guide systems made of aluminum with non-rotating precision steel shafts meet the high performance requirements needed for the construction and operation of machines.

In combination with the ball-guided carriages or roller-guided carriages offered in various designs and with an extensive range of accessories, the product range offers solutions for many potential applications and the construction of complex multi-axis systems.

Aluminum shaft slide

The shaft slides manufactured by isel are ideal for the set-up of complex multi-axis systems for handling and processing. Many application areas are covered by a wide range of models.

All models can be manufactured with different profile lengths (of 70, 100, 150, and 200 mm)

The adjustment of the slide is carried out by means of self-locking adjusting screws. For this purpose, the rows of balls and shafts or wires are set against each other and consequently pre-stressed. The carriages are set to the respective pre-loads at the factory. As an option, all shaft slides are available in a stainless version.

To fasten transport loads, slide plates etc., the shaft slides are supplied with T-grooves or fastening holes.

Ball circuits are positioned inside the linear slide. Load-bearing balls each run between two ground steel wires and the guide shaft.

The ball deflection is equipped with a reinforcement made of glass fiber.

Two-sided lubrication option for the ball circuits.

Precision steel shafts reaching a hardness value of 60 ± 2 HRC are used as guide rails. All LFS-8 versions are optionally available with stainless steel shafts.

The base supports of all linear guides are thrust with aluminum profiles according to the standard DIN EN 12020-2 which are provided with T-grooves and/or have fastening holes permitting their fastening inside the profile base

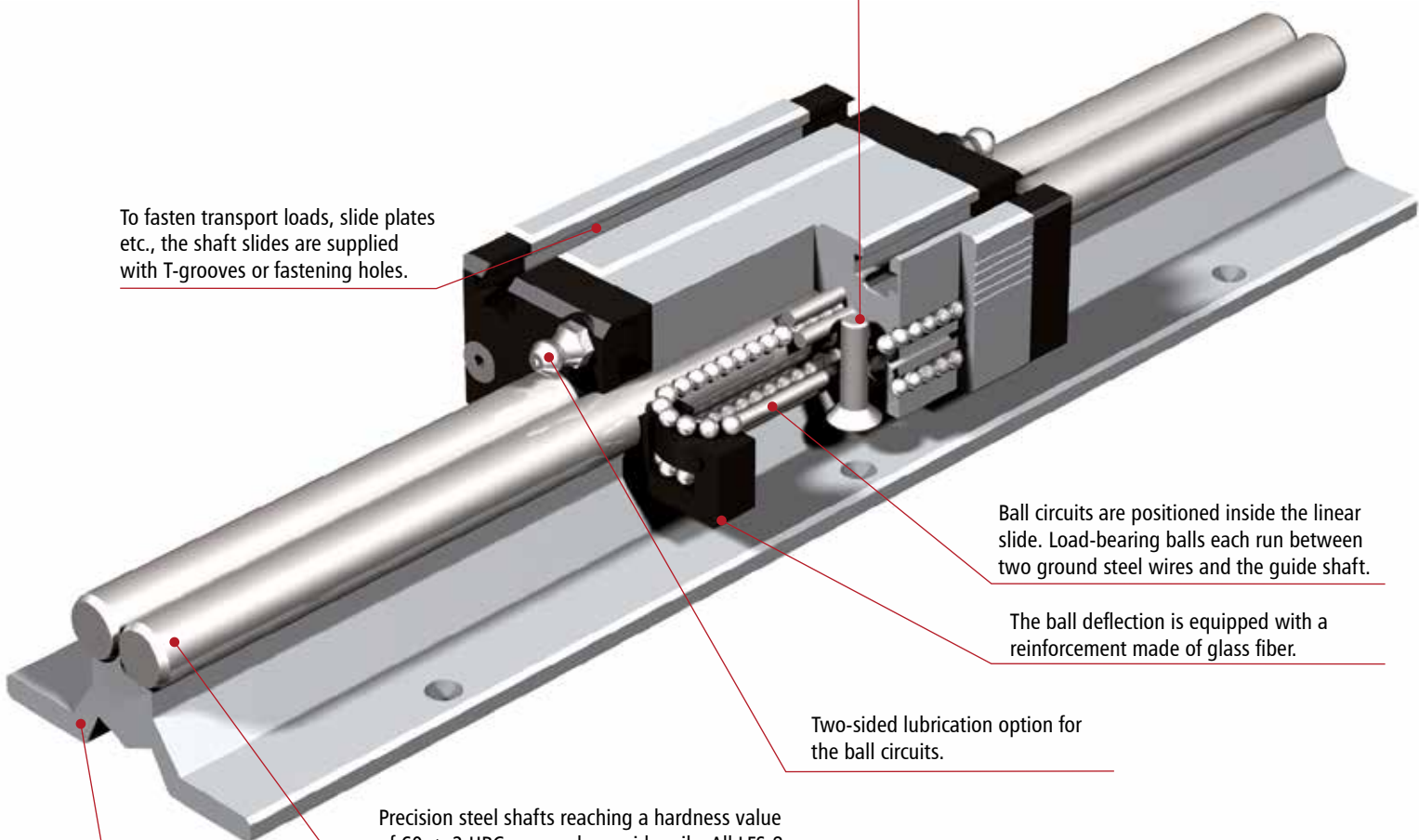



Load capacity and life-time

Assembly position

Generally speaking, the assembly position of the linear guides can be freely selected. What must be considered is just the fact that all exercised forces and moments are below the maximum values for the respective axes.

Temperatures

All linear guides are designed for continuous operation in ambient temperatures of up to 60 °C. In short-term operation, temperatures of a maximum of 80 °C are permissible. The linear guides are not suitable for temperatures below freezing.

Straightness / Torsion

The aluminum profiles used are extruded profiles, which due to the manufacturing process show deviations in terms of straightness and torsion. The tolerance of this deviation is defined according to the standard DIN EN 12020-2. In the worst case, the deviations of the linear guides correspond to these limit values. However, they are usually undercut. In order to achieve the desired guide accuracy, it is necessary to carry out the alignment of the guide by means of leveling plates and/or to clamp it on a suitably precisely machined support surface. In this manner, tolerances of 0.1 mm/1000 mm can be achieved.

Fundamentals of load capacity and service life

The dimensioning of a linear guide is based on the load capacity of the single elements. The carrying capacity is described by:

- the dynamic load rating C
- the static load rating C0
- the static moments M0X , M0Y and M0Z

The basis of the dynamic load ratings according to the DIN standard is a nominal service life of 100,000 m displacement. Suppliers from the Far East often state the load ratings for a nominal service life of 50,000 m; this results in load ratings which are 20% higher than the ratings according to the DIN standard.

Dynamic Capacity

The fatigue behaviour of the material determines its dynamic load capacity. The service life - the fatigue period - depends on the following factors:

- the load of the linear guide
- the travel speed of the linear guide
- the statistical randomness of the first occurrence of damage

Service life

The service life is understood to mean the service life which is actually achieved by a linear guide.

The service life may deviate from the calculated service life. The following situation can result in a premature failure due to wear or in fatigue:

- An existing misalignment between the guide rails or the guide elements
- The soiling of the guide rails
- Insufficient lubrication
- Oscillating movement with very small strokes (corrugation)
- Vibrations during the shutdown (corrugation)

Because of the variety of the assembly and operating conditions, it is not possible to determine the service life of a linear guide exactly in advance. The surest way to obtain an accurate estimate of the service life is still a comparison with similar assembly cases.



Linear guide rail type LFS-8-1 / LFS-8-2



Linear guide rails

- W 30 x H 20 mm (LFS-8-1)
W 30 x H 32.5 mm (LFS-8-2)
- 2 precision steel shafts Ø 8 mm
- twist-proof
- Aluminum shaft mounting profile, natural anodized
- Fastening from below by using M6 threaded rails in the T-slot indentation
- Conditionally self-supporting
- Special lengths offered upon request
- Weights: approx. 1.6 kg/m (LFS-8-1)
approx. 2.0 kg/m (LFS-8-2)

Options:

- Stainless construction
- Equipped with through-holes for M6 (this applies only to the type LFS-8-1)

Carriage

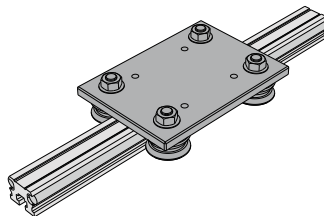

LW 6

- L 125 x W 90 x H 7.7 mm
- Ground steel plate
- 4 rollers Ø 31 mm, lubricated over the entire service life
- Clearance-free adjustment possible
- Weight: approx. 1 kg

Part No.: 223011

Slide made of aluminum

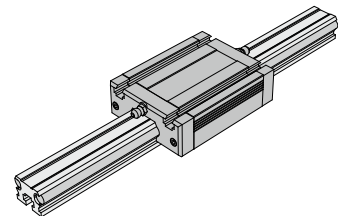

- Equipped with a recirculating ball guide
- Milled clamping surface
- T-slot inserts M6
- Central lubrication option
- Clearance-free adjustment possible

Option:

- Stainless construction

WS 1/70

- L 96 x W 72 x H 28.5 mm
- Weight: approx. 0.4 kg
- Part No.: 2231000070
- stainless: 223101 0070

WS 1

- L 126 x W 72 x H 28.5 mm
- Weight: approx. 0.5 kg
- Part No.: 223100
- stainless: 223101

Order key

	23500X	XXXX	
LFS-8-1 / standard	= 0	<u>Length LFS-8-1</u>	<u>Length LFS-8-2</u>
LFS-8-1 / stainless	= 1	in mm (inside a grid of 100mm)	in mm (inside a grid of 100mm)
LFS-8-2 / standard	= 2	for example 0029 = L 298	for example 0298 = L 298
LFS-8-2 / stainless	= 3	0299 = L 2998	2998 = L 2998

Steel shaft length: Total length L - 3 mm

Profile up to a length of 6000 mm available without butt joint, with divided steel shafts.

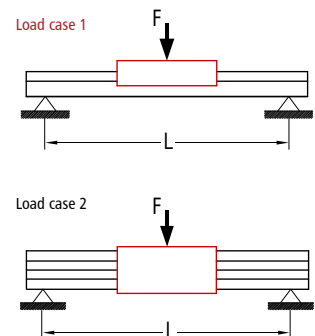
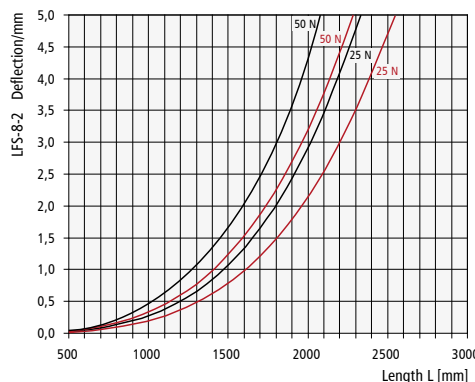
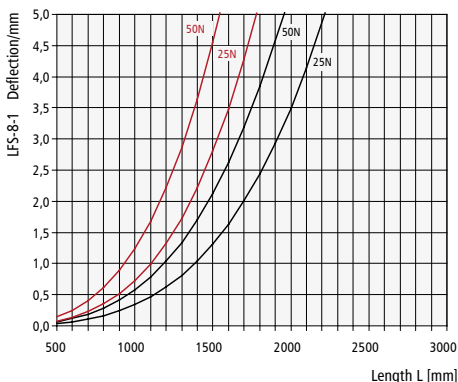



Dimensional drawing

LFS-8-1 and/or LFS-8-2 with aluminum slide type WS 1/70 or WS 1

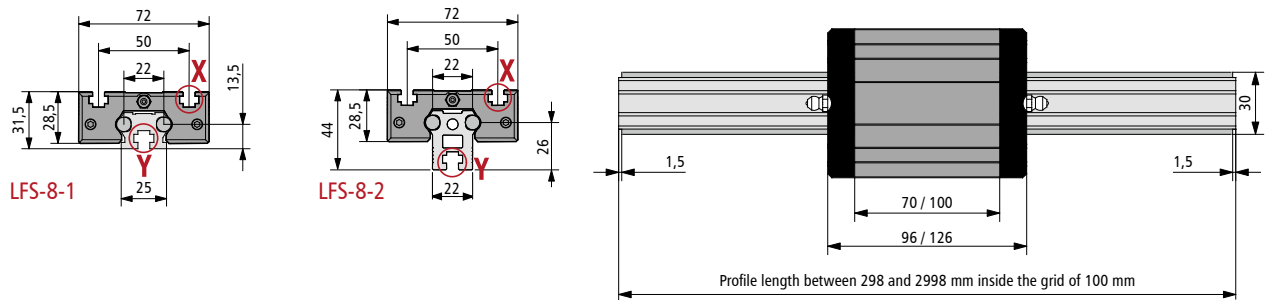

LFS-8-1 or LFS-8-2 with carriage type LW 6

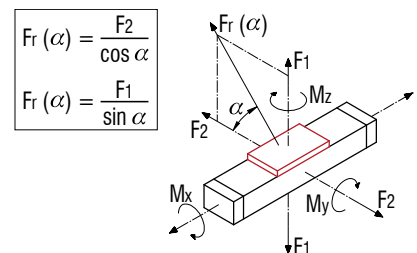
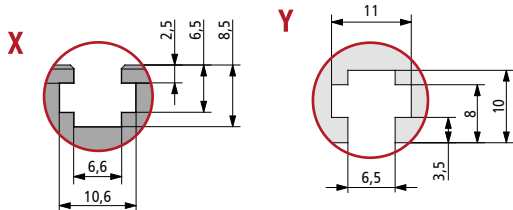
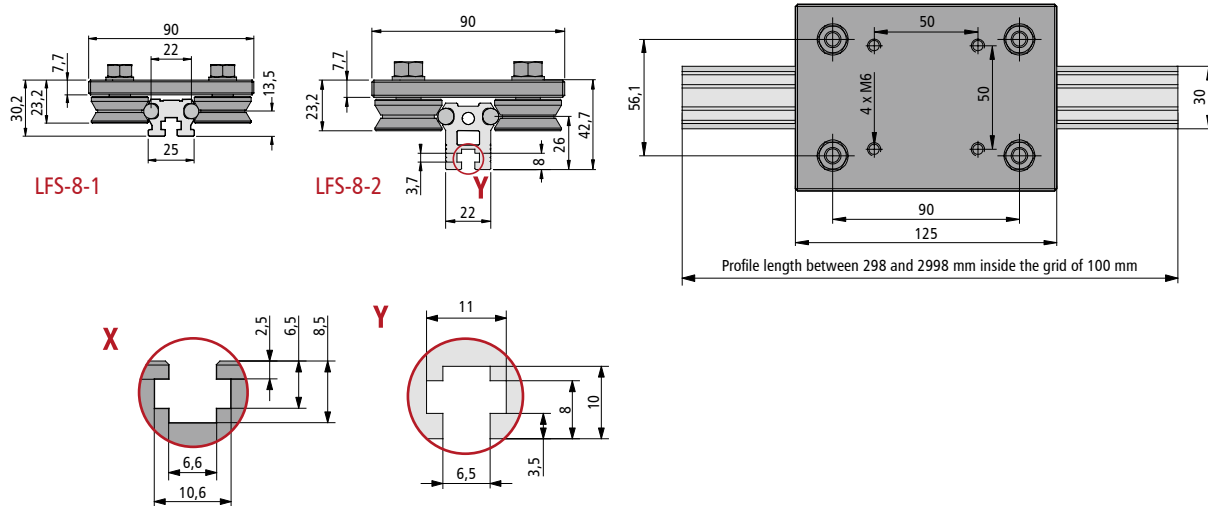

Load data

Aluminum slide type WS 1/70

C ₀	3114 N
C	1846 N
F ₁ static	2659 N
F ₁ dynamic	1576 N
F ₂ static	3114 N
F ₂ dynamic	1846 N
M _x static	37.3 Nm
M _y static	100.5 Nm
M _z static	117.6 Nm
M _x dynamic	22.1 Nm
M _y dynamic	59.5 Nm
M _z dynamic	69.7 Nm

Aluminum slide type WS 1

C ₀	4590 N
C	2390 N
F ₁ static	3920 N
F ₁ dynamic	2041 N
F ₂ static	4590 N
F ₂ dynamic	2390 N
M _x static	55.0 Nm
M _y static	148.1 Nm
M _z static	173.4 Nm
M _x dynamic	28.6 Nm
M _y dynamic	77.1 Nm
M _z dynamic	90.2 Nm

Carriage type LW 6

C ₀	2160 N
C	4000 N
F ₁ static	4320 N
F ₁ dynamic	3792 N
F ₂ static	2160 N
F ₂ dynamic	4000 N
M _x static	121.1 Nm
M _y static	194.4 Nm
M _z static	97.2 Nm
M _x dynamic	106.3 Nm
M _y dynamic	170.6 Nm
M _z dynamic	180.0 Nm



Linear guide rail type LFS-8-3



Linear guide rail

- W 115 x H 25.5 mm
- 2 precision steel shafts Ø 8 mm
- Particularly twist-proof
- Aluminum shaft mounting profile, natural anodized
- Fastening from above by using through-holes for M6 inside a grid of 100 mm
- Conditionally self-supporting
- Special lengths offered upon request
- Weight: approx. 3.2 kg/m
- Option: stainless construction

Carriage

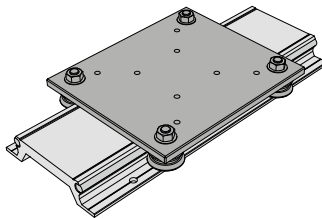

LW 7

- L 175 x W 150 x H 7.5 mm
 - Ground steel plate
 - 4 rollers Ø 31, lubricated over the entire service life
 - Clearance-free adjustment possible
 - Weight: approx. 2 kg
- Part No.: **223012**

Slide made of aluminum

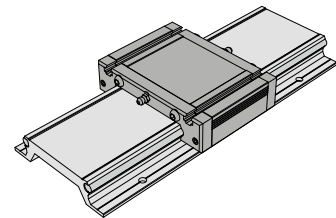

- Equipped with a recirculating ball guide
- Milled clamping surface
- T-slot inserts M6
- Central lubrication option
- Clearance-free adjustment possible

Option:

- Stainless construction

Order key

LFS-8-3 / Standard = 4 ^{23500X} ^{XXXX} Length LFS-8-3 for example 0029 = L 298
 LFS-8-3 / stainless = 5 in mm (inside a grid of 100 mm) 0299 = L 2998

Steel shaft length: Total length L - 1 mm
 Profile up to a length of 6000 mm available without butt joint, with divided steel shafts.

WS 3/70

- L 96 x W 130 x H 32 mm
 - Weight: approx. 0.5 kg
- Part No.: **223103 0070**
 stainless: **223103 1070**

WS 3

- L 176 x W 130 x H 32 mm
 - Weight: approx. 0.9 kg
- Part No.: **223103**
 stainless: **223103 1000**

Deflection

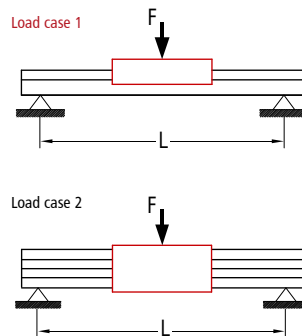
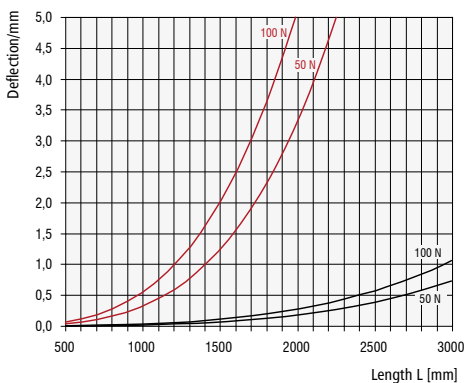



Dimensional drawing

LFS-8-3 with aluminum slide type WS3/70 and/or WS3

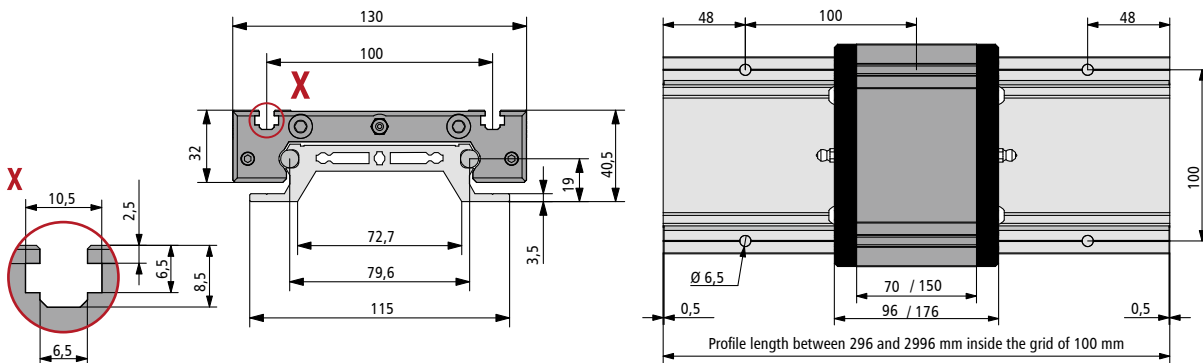

LFS-8-3 with carriage type LW7

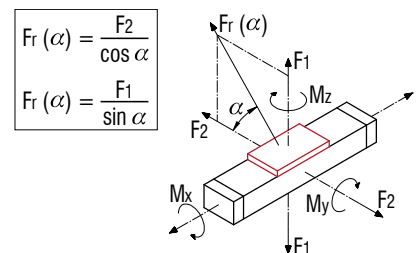
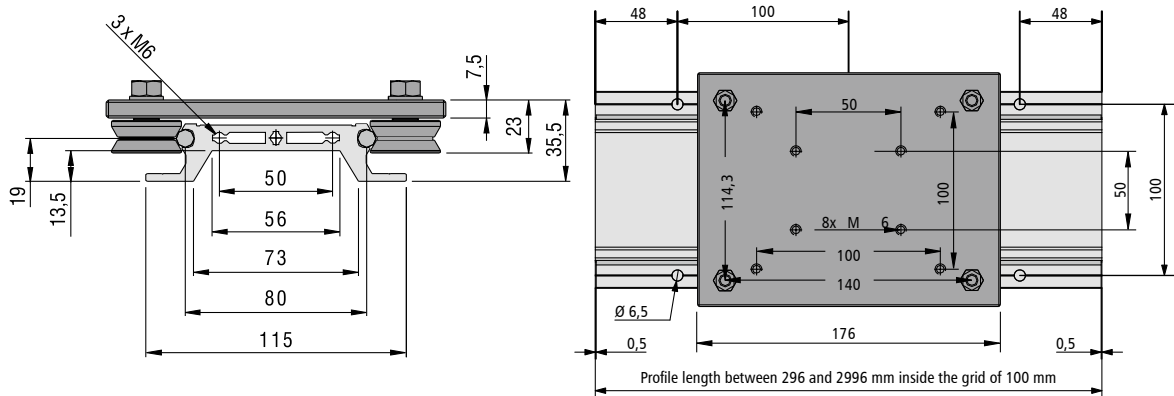

Load data

Aluminum slide type WS 3/70		Aluminum slide type WS 3		Carriage type LW 7	
C ₀	3141 N	C ₀	6945 N	C ₀	2160 N
C	1879 N	C	3190 N	C	4000 N
F ₁ static	2682 N	F ₁ static	5931 N	F ₁ static	4320 N
F ₁ dynamic	1604 N	F ₁ dynamic	2724 N	F ₁ dynamic	3792 N
F ₂ static	3141 N	F ₂ static	6945 N	F ₂ static	2160 N
F ₂ dynamic	1879 N	F ₂ dynamic	3190 N	F ₂ dynamic	4000 N
M _x static	115.7 Nm	M _x static	255.9 Nm	M _x static	246.8 Nm
M _y static	105.3 Nm	M _y static	232.8 Nm	M _y static	302.4 Nm
M _z static	123.3 Nm	M _z static	272.5 Nm	M _z static	151.2 Nm
M _x dynamic	69.2 Nm	M _x dynamic	117.5 Nm	M _x dynamic	216.7 Nm
M _y dynamic	62.9 Nm	M _y dynamic	106.9 Nm	M _y dynamic	265.4 Nm
M _z dynamic	73.7 Nm	M _z dynamic	125.1 Nm	M _z dynamic	280.0 Nm



Linear guide rail type LFS-8-4



Illustration:
LFS-8-4 equipped with
2 steel shafts and an
aluminum slide

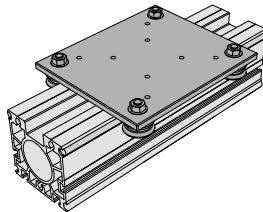

Illustration:
LFS-8-4 equipped with 4 steel shafts
and two aluminum slides (optional)

Linear guide rail

- W 80 x H 80 mm
- 4 precision steel shafts Ø 8 mm
- twist-proof
- Aluminum shaft mounting profile, natural anodized
- Fastening from below by using M6 threaded rails in the T-slot inserts or at the top by using M8 bores
- Lateral T-grooves for the fastening of the limit switch
- Conditionally self-supporting
- Special lengths offered upon request
- Weight: approx. 7.2 kg/m
- Options: stainless construction equipped with 2 steel shafts 2. slide and/or carriage

Carriage



LW 7

- L 175 x W 150 x H 7.5 mm
 - Ground steel plate
 - 4 rollers Ø 31 mm, lubricated over the entire service life
 - Clearance-free adjustment possible
 - Weight: approx. 2 kg
- Part No.: **223012**

Slide made of aluminum

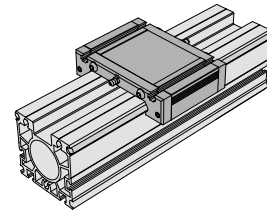

- Milled clamping surface
- T-slot inserts M6
- Central lubrication option
- Clearance-free adjustment possible

Option:

- Stainless construction

WS 3/70

- L 96 x W 130 x H 32 mm
 - Weight: approx. 0.5 kg
- Part No.: **223103 0070**
stainless: **223103 1070**

WS 3

- L 176 x W 130 x H 32 mm
 - Weight: approx. 0.9 kg
- Part No.: **223103**
stainless: **223103 1000**

Order key

23500X XXXX
 LFS-8-4 / Standard = 6 Length LFS-8-4 for example 0029 = L 298
 LFS-8-4 / stainless = 7 in mm (inside the grid of 100mm) 0299 = L 2998

Steel shaft length: total length L -3mm

Profile available up to a length of 6,000 mm without a butt joint, divided steel shafts.

Deflection

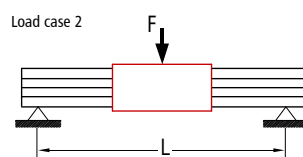
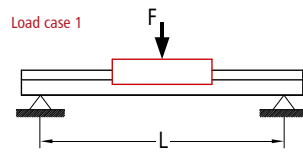
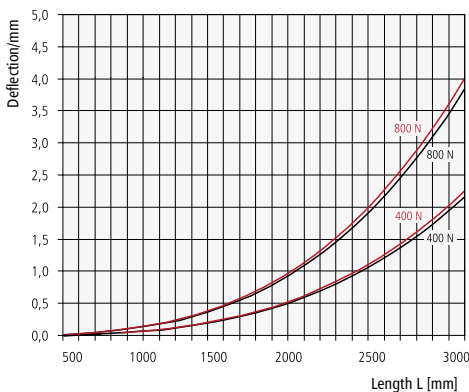



Dimensional drawing

LFS-8-4 with aluminum slide type WS3/70 and/or WS3

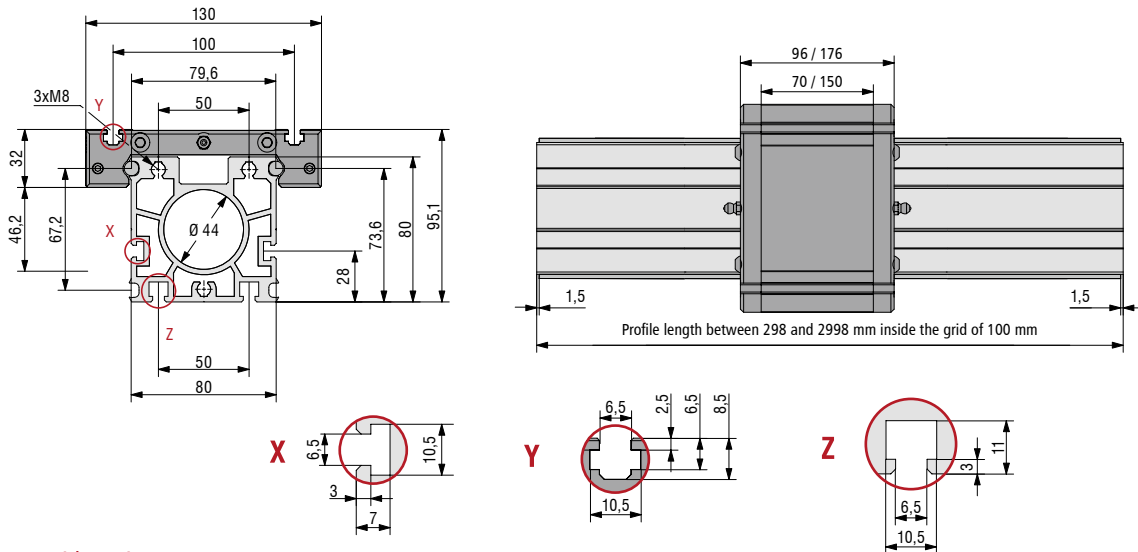

LFS-8-4 with carriage type LW7

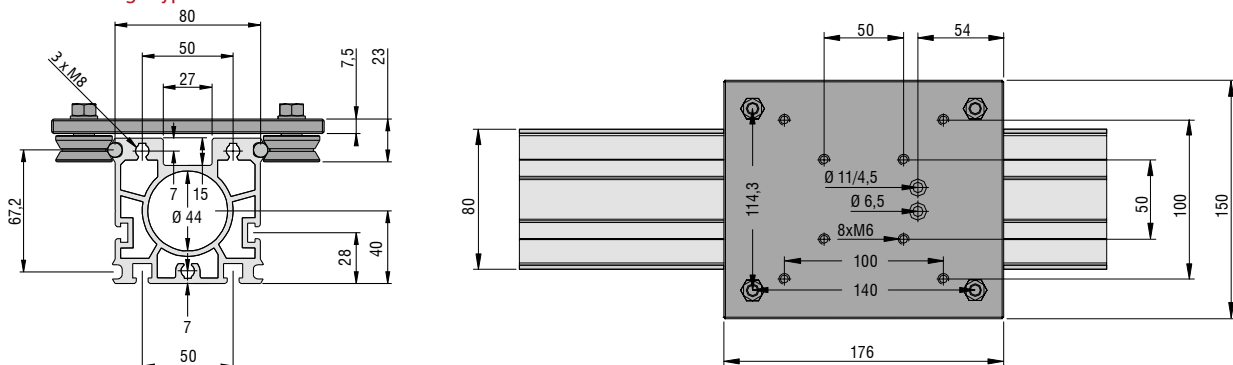

$$Fr(\alpha) = \frac{F_2}{\cos \alpha}$$

$$Fr(\alpha) = \frac{F_1}{\sin \alpha}$$

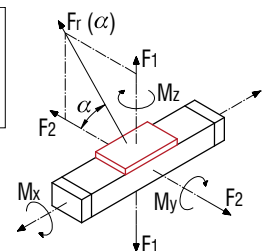

Load data

Aluminum slide type WS 3/70

C ₀	3141 N
C	1879 N
F ₁ static	2682 N
F ₁ dynamic	1604 N
F ₂ static	3141 N
F ₂ dynamic	1879 N
M _x static	115.7 Nm
M _y static	105.3 Nm
M _z static	123.3 Nm
M _x dynamic	69.2 Nm
M _y dynamic	62.9 Nm
M _z dynamic	73.7 Nm

Aluminum slide type WS 3

C ₀	6945 N
C	3190 N
F ₁ static	5931 N
F ₁ dynamic	2724 N
F ₂ static	6945 N
F ₂ dynamic	3190 N
M _x static	255.9 Nm
M _y static	232.8 Nm
M _z static	272.5 Nm
M _x dynamic	117.5 Nm
M _y dynamic	106.9 Nm
M _z dynamic	125.1 Nm

Carriage type LW 7

C ₀	2160 N
C	4000 N
F ₁ static	4320 N
F ₁ dynamic	3792 N
F ₂ static	2160 N
F ₂ dynamic	4000 N
M _x static	246.8 Nm
M _y static	302.4 Nm
M _z static	151.2 Nm
M _x dynamic	216.7 Nm
M _y dynamic	265.4 Nm
M _z dynamic	280.0 Nm



Linear guide rail type LFS-8-7

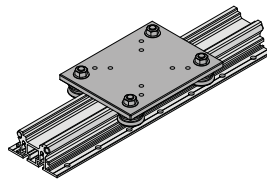

Illustration:
Linear guide rails and
Linear guide carriage

Linear guide rail

- W 78 x H 36 mm
- 2 precision steel shafts Ø 8 mm
mounting grid 100 mm
- shaft housing contour
(terminal connection)
- aluminium profile rail with T-slots,
natural anodized
- conditionally cantilevered
- Standard lengths in 100 mm
increments up to 3 m
- Special lengths offered upon request
- Weight: 2,9 kg/m

Carriage



LW 10

- L 150 x W 115 x H 7,7 mm
 - Grounded steel plate
 - 4 castors Ø 31 mm
 - Lubricated for life
 - Adjustable for no play
 - Weight: 1.47 kg
- Part no.: 223 014

Slide made of aluminum

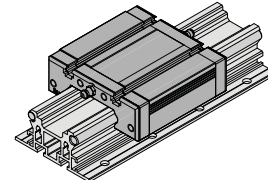

WS 11/70

- with 8 steel inserts
L 96 x W 96 x H 32 mm
 - 4 ball circuits, adjustable for
no play
 - Grease nipple frontally
 - Weight: 0.40 kg
- Part no.: 223111 0070

Ordering key

235 012 XXXX

Length LFS-8-7
in mm (inside the grid of 100mm)

for example 0019 = L 196
0299 = L 2996

Deflection

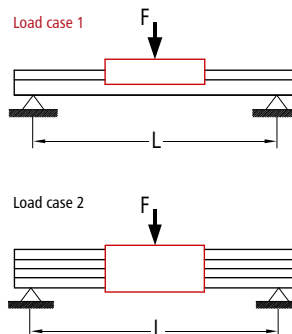
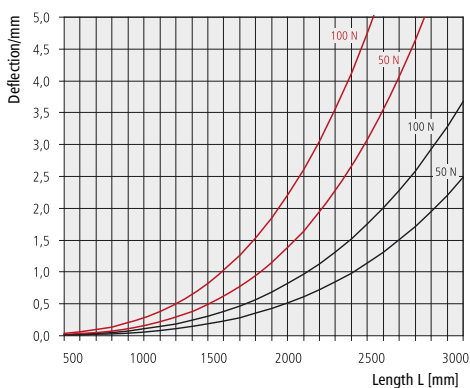

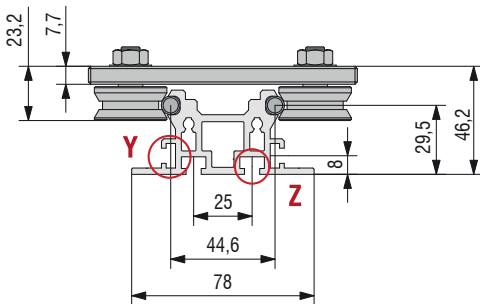
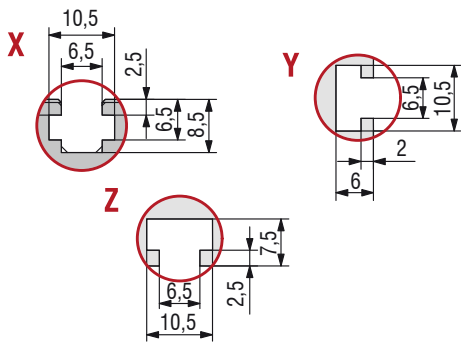
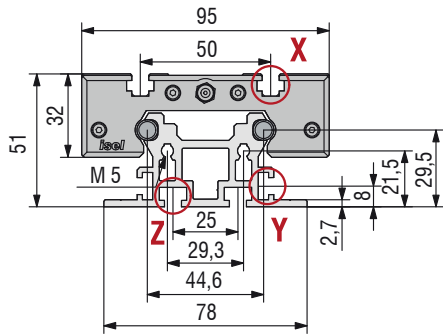

LFS-8-7 with aluminum slide type WS11/70

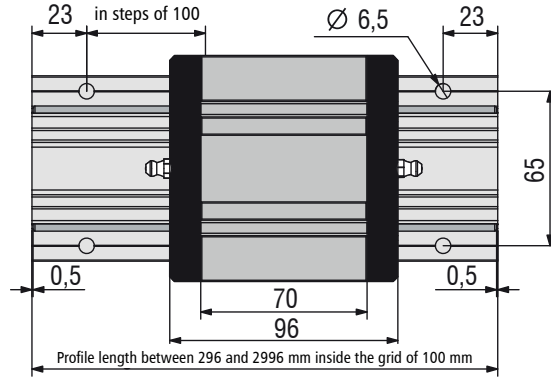

LFS-8-7 with carriage type LW10

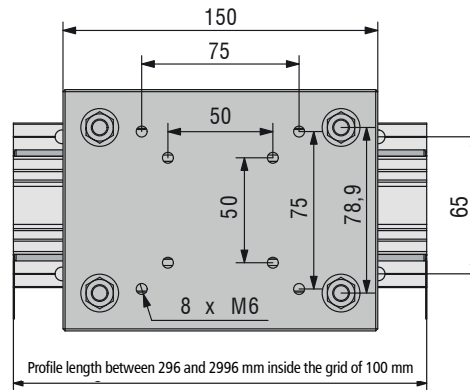

Load data

$$F_r(\alpha) = \frac{F_2}{\cos \alpha}$$

$$F_r(\alpha) = \frac{F_1}{\sin \alpha}$$

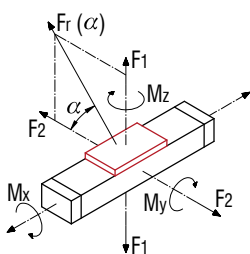

Carriage type LW 10

C ₀	2160 N
C	4000 N
F ₁ static	4320 N
F ₁ dynamic	3792 N
F ₂ static	2160 N
F ₂ dynamic	4000 N
M _x static	170,4 Nm
M _y static	248,4 Nm
M _z static	124,2 Nm
M _x dynamic	149,5 Nm
M _y dynamic	218,0 Nm
M _z dynamic	230,0 Nm

Aluminum slide type WS 11/70

C ₀	3114 N
C	1846 N
F ₁ static	2659 N
F ₁ dynamic	1576 N
F ₂ static	3114 N
F ₂ dynamic	1846 N
M _x static	67,3 Nm
M _y static	100,5 Nm
M _z static	117,6 Nm
M _x dynamic	39,9 Nm
M _y dynamic	59,5 Nm
M _z dynamic	69,7 Nm



Linear guide rail type LFS-12-1



Shaft mounting blocks

- Ø40 mm, hole distance 28 mm
 - Zinc cast, VE 10 pieces
- Part No.: 221501

Linear guide rail

- W 40 x H 27 mm
- Precision steel shafts Ø 12 mm
- twist-proof
- Aluminum shaft mounting blocks
- Attachment from above by using through-holes for M6 in the mounting blocks
- Any guide length up to 3 m
- Special lengths offered upon request
- Weight: approx. 1.9 kg/m

Carriage

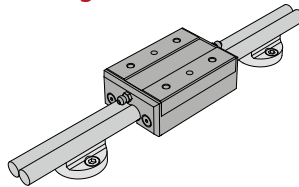

LW 3

- L 125 x W 85 x H 7.7 mm
 - Ground steel plate
 - Weight: approx. 0.93 kg
- Part No.: 223008

Steel slide

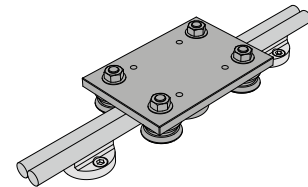

LS 1

- L 91 x W 60 x H 32 mm
 - Ground clamping surface
 - Weight: approx. 0.8 kg
- Part No.: 223006

Order key

227312 XXXX

for example 0298 = L 298

2998 = L 2,998

Length in mm (in a grid of 100mm)

Non-standard lengths are available upon request!

The part no. exclusively refers to one steel shaft.

Shaft receiving block

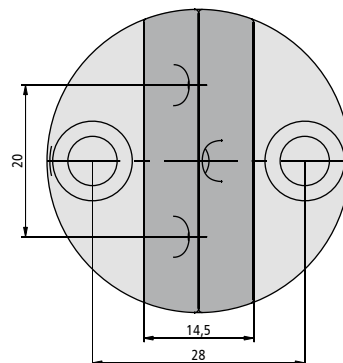
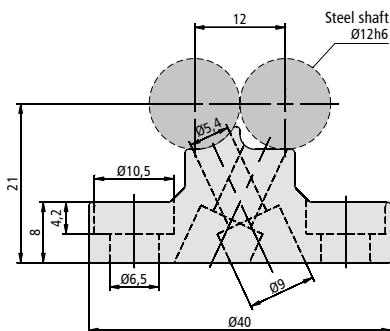



Dimensional drawing

2 x LFS-12-1 equipped with carriage LW 3 with shaft mounting blocks

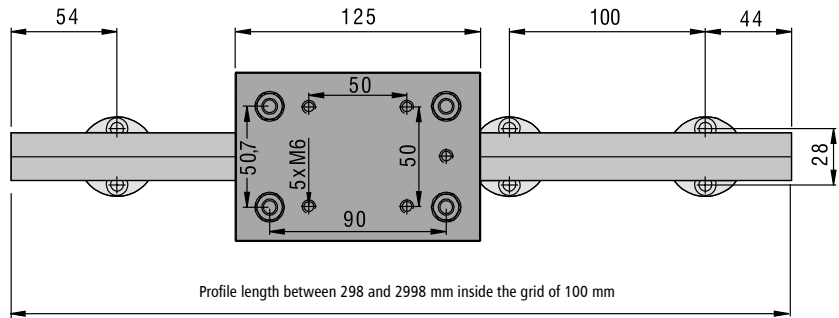
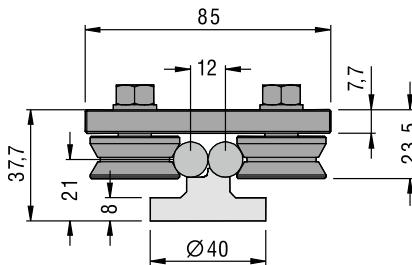

2 x LFS-12-1 equipped with a steel slide LS 1 equipped with shaft mounting blocks

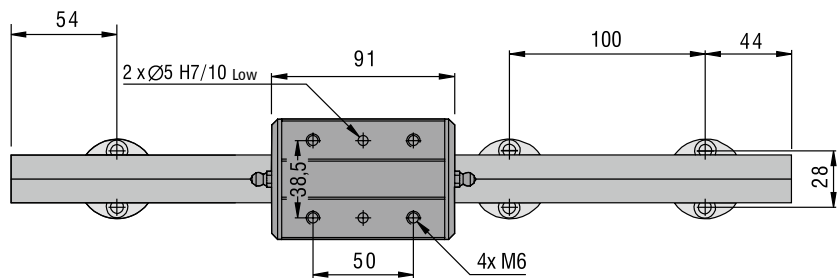
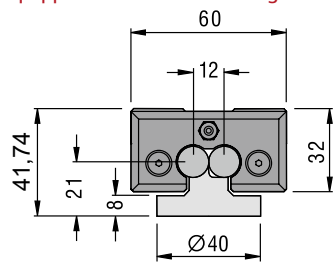

Load data

$$F_r(\alpha) = \frac{F_2}{\cos \alpha}$$

$$F_r(\alpha) = \frac{F_1}{\sin \alpha}$$

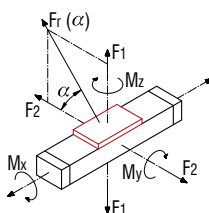

Carriage type LW 3

C ₀	2160 N
C	4000 N
F ₁ static	4320 N
F ₁ dynamic	3846 N
F ₂ static	2160 N
F ₂ dynamic	4000 N
M _x static	109.5 Nm
M _y static	194.4 Nm
M _z static	97.2 Nm
M _x dynamic	97.4 Nm
M _y dynamic	173.0 Nm
M _z dynamic	180.0 Nm

Steel slide type LS 1

C ₀	3508 N
C	2105 N
F ₁ static	3549 N
F ₁ dynamic	2130 N
F ₂ static	3508 N
F ₂ dynamic	2105 N
M _x static	36.2 Nm
M _y static	129.0 Nm
M _z static	127.5 Nm
M _x dynamic	21.7 Nm
M _y dynamic	77.4 Nm
M _z dynamic	76.5 Nm



Dimensional drawing

LFS-12-11 equipped with carriage type LW 5

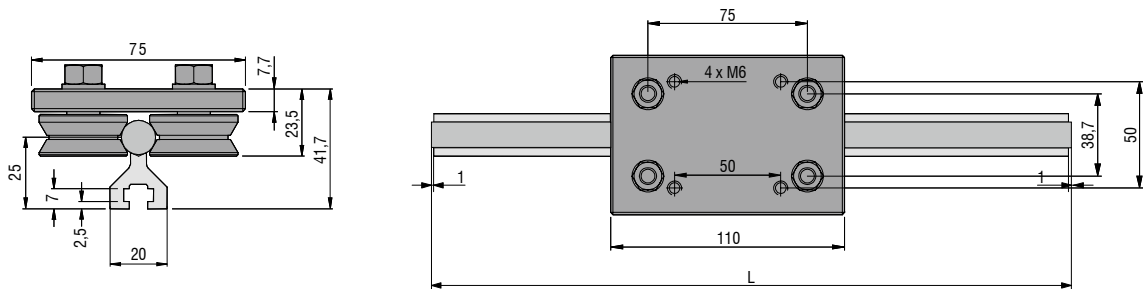

LFS-12-11 equipped with aluminum slide type WS 6/70 and/or WS 6

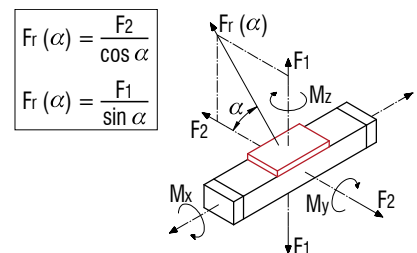
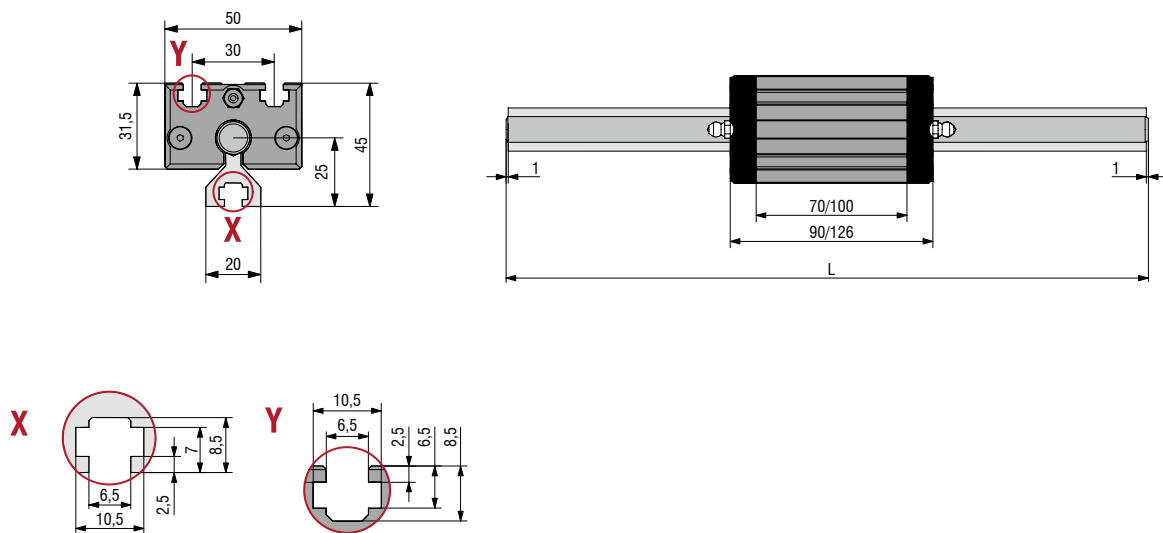

Load data

Carriage type LW 5

C ₀	2160 N
C	4000 N
F ₁ static	4320 N
F ₁ dynamic	3846 N
F ₂ static	2160 N
F ₂ dynamic	4000 N
M _x static	-
M _y static	162.0 Nm
M _z static	81.0 Nm
M _x dynamic	-
M _y dynamic	144.2 Nm
M _z dynamic	150.0 Nm

Aluminum slide type WS 6/70

C ₀	3303 N
C	1873 N
F ₁ static	2821 N
F ₁ dynamic	1599 N
F ₂ static	3303 N
F ₂ dynamic	1873 N
M _x static	-
M _y static	105.3 Nm
M _z static	123.3 Nm
M _x dynamic	-
M _y dynamic	59.7 Nm
M _z dynamic	69.9 Nm

Aluminum slide type WS 6

C ₀	4868 N
C	2426 N
F ₁ static	4157 N
F ₁ dynamic	2071 N
F ₂ static	4868 N
F ₂ dynamic	2426 N
M _x static	-
M _y static	155.2 Nm
M _z static	181.7 Nm
M _x dynamic	-
M _y dynamic	77.3 Nm
M _z dynamic	90.5 Nm



Linear guide rail type LFS-12-2



Linear guide rail

- W 62 x H 31 mm
- 2 precision steel shafts Ø 12 mm
- twist-proof
- Aluminum shaft mounting profile, natural anodized
- High degree of parallelism thanks to the patented shaft mounting contour
- High guiding accuracy
- Fastening from above or from below by using Ø 6.5 holes inside the grid of 100 mm a flat surface
- Lengths in the grid of 100 mm
- Max. length up to 2998 mm
- Special lengths offered upon request
- Weight: approx. 3.3 kg/m

Carriage

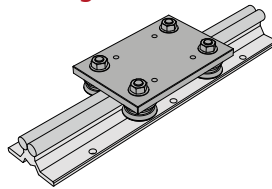

LW 3

- L 125 x W 85 x H 7.7 mm
 - Ground steel plate
 - Weight: approx. 0.93 kg
- Part No.: **223008**

Steel slide

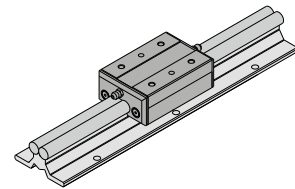

LS 1

- L 91 x W 60 x H 32 mm
 - Ground clamping surface
 - Weight: approx. 0.8 kg
- Part No.: **223006**

Order key

235200 XXXX

for example 0298 = L 298

2998 = L 2,998

Length in mm (in a grid of 100mm)

Profile length = total length L - 2 mm

Deflection

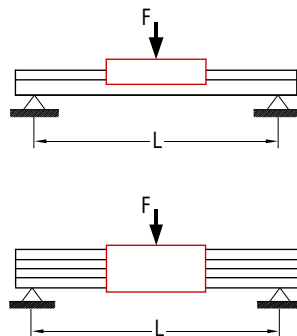
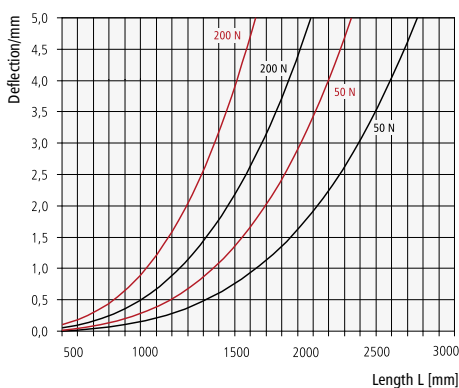



Dimensional drawing

LFS-12-2 equipped with a carriage type LW 3

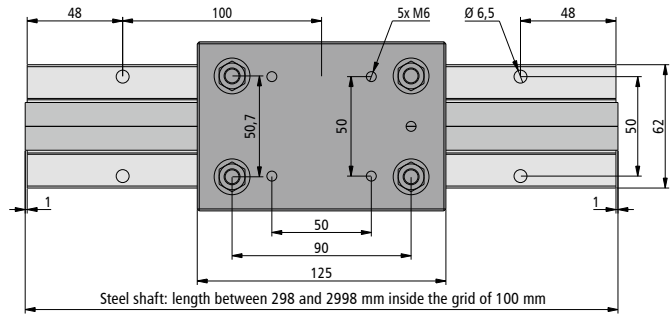
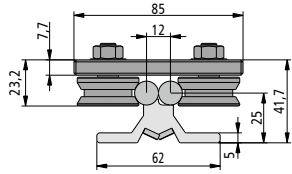

LFS-12-2 equipped with a steel slide type LS 1

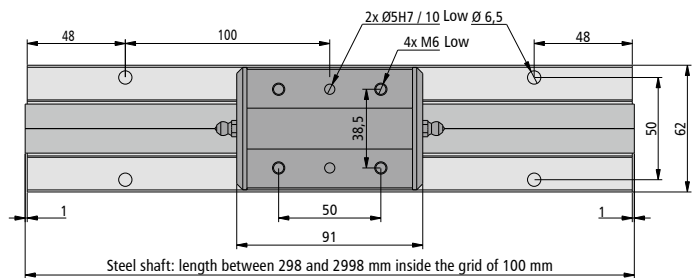
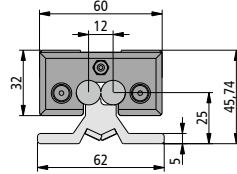

Load data

$$F_r(\alpha) = \frac{F_2}{\cos \alpha}$$

$$F_r(\alpha) = \frac{F_1}{\sin \alpha}$$

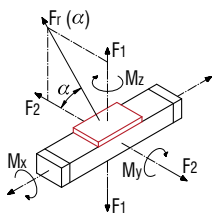

Carriage type LW 3

C ₀	2160 N
C	4000 N
F ₁ static	4320 N
F ₁ dynamic	3846 N
F ₂ static	2160 N
F ₂ dynamic	4000 N
M _x static	109.5 Nm
M _y static	194.4 Nm
M _z static	97.2 Nm
M _x dynamic	97.4 Nm
M _y dynamic	173.0 Nm
M _z dynamic	180.0 Nm

Steel slide type LS 1

C ₀	3508 N
C	2105 N
F ₁ static	3549 N
F ₁ dynamic	2130 N
F ₂ static	3508 N
F ₂ dynamic	2105 N
M _x static	36.2 Nm
M _y static	129.0 Nm
M _z static	127.5 Nm
M _x dynamic	21.7 Nm
M _y dynamic	77.4 Nm
M _z dynamic	76.5 Nm



Linear guide rail type LFS-12-3



Linear guide rail

- W 90 x H 31 mm
- 2 precision steel shafts Ø 12 mm
- twist-proof
- Aluminum shaft mounting profile, natural anodized
- Increased shaft distance enabling the reception of higher moments
- Fastening from above or from below by using through-holes for M6 inside the grid of 100 mm
- Any guide length possible
- Weight: approx. 3.9 kg/m

Order key

235300 XXXX
 for example 0298 = L 298
 2998 = L 2,998

Length in mm (in a grid of 100mm)

Profile length = total length L - 2 mm
 Special lengths over 3000 mm equipped with rod connection upon request.

Carriage

- Clearance-free adjustment possible
- 4 rollers Ø 31 mm, lubricated over the entire service life

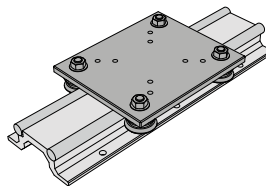

LW 8

- L 150 x W 125 x H 7.5 mm
 - Ground steel plate
 - Weight: 1.51 kg
- Part No.: 223013

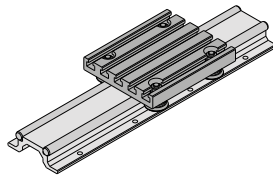

LW 2

- L 150 x W 125 x H 34.5 mm
 - Aluminum T-slot plate
 - Weight: 0.97 kg
- Part No.: 223005

Linear guide slide

- Ground steel plate
- Central lubrication option
- Clearance-free adjustment possible

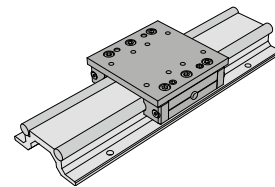

WS 7/70

- L 100 x W 100 x H 32 mm
 - Weight: approx. 0.8 kg
- Part No.: 223107 0070

WS 7

- L 200 x W 100 x H 32 mm
 - Weight: approx. 1.7 kg
- Part No.: 223107

Deflection

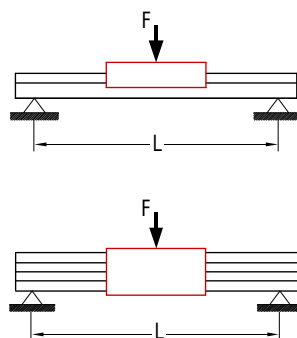
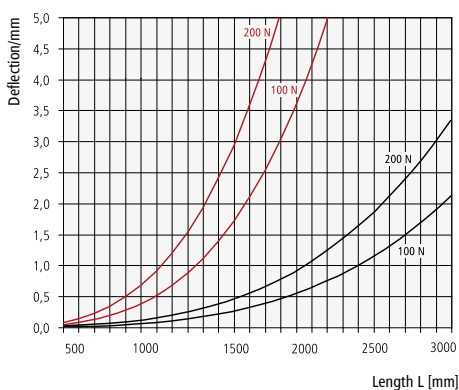



Dimensional drawing

LFS-12-3 equipped with carriage type LW 8

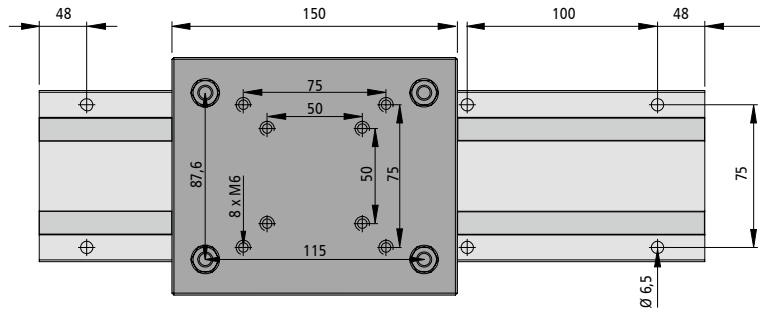
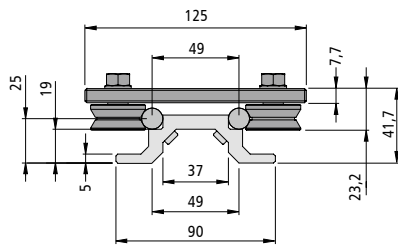

LFS-12-3 equipped with carriage type LW 2

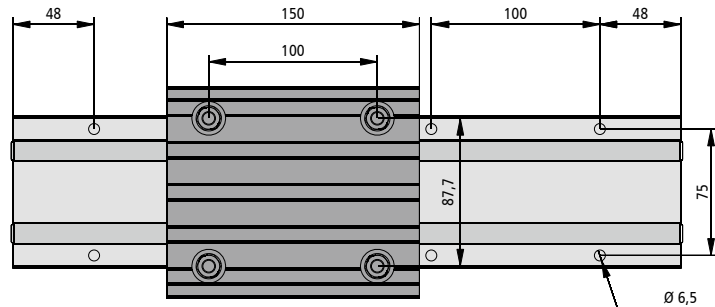
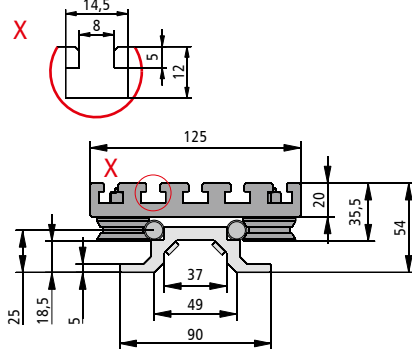

LFS-12-3 equipped with aluminum slide type WS 7

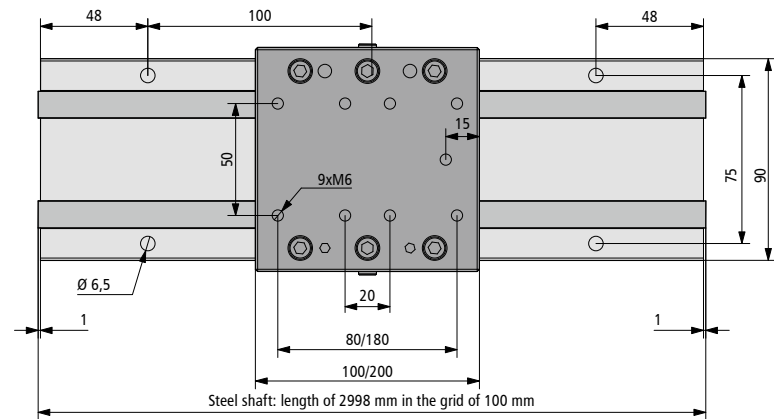
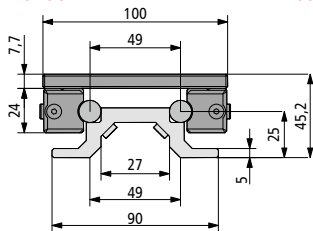

$$F_r(\alpha) = \frac{F_2}{\cos \alpha}$$

$$F_r(\alpha) = \frac{F_1}{\sin \alpha}$$

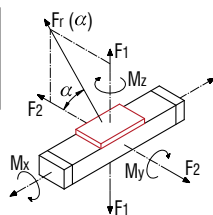

Load data

Carriage type LW 8		Carriage type LW 2		Linear guide slide type WS 7/70		Linear guide slide type WS 7	
C ₀	2160 N	C ₀	3114 N	C ₀	3303 N	C ₀	7303 N
C	4000 N	C	1846 N	C	1873 N	C	3179 N
F ₁ static	4320 N	F ₁ static	2659 N	F ₁ static	2821 N	F ₁ static	6237 N
F ₁ dynamic	3846 N	F ₁ dynamic	1576 N	F ₁ dynamic	1599 N	F ₁ dynamic	2715 N
F ₂ static	2160 N	F ₂ static	3114 N	F ₂ static	3303 N	F ₂ static	7303 N
F ₂ dynamic	4000 N	F ₂ dynamic	1846 N	F ₂ dynamic	1873 N	F ₂ dynamic	3179 N
M _x static	189.2 Nm	M _x static	216.0 Nm	M _x static	82.0 Nm	M _x static	181.2 Nm
M _y static	248.4 Nm	M _y static	100.5 Nm	M _y static	105.3 Nm	M _y static	232.8 Nm
M _z static	124.2 Nm	M _z static	108.0 Nm	M _z static	123.3 Nm	M _z static	272.5 Nm
M _x dynamic	168.4 Nm	M _x dynamic	168.4 Nm	M _x dynamic	46.4 Nm	M _x dynamic	78.8 Nm
M _y dynamic	221.1 Nm	M _y dynamic	192.3 Nm	M _y dynamic	59.7 Nm	M _y dynamic	101.3 Nm
M _z dynamic	230.0 Nm	M _z dynamic	200.0 Nm	M _z dynamic	69.9 Nm	M _z dynamic	118.6 Nm



Linear guide rail type LFS-12-10



Linear guide rail

- W 36 x H 24.5 mm
- 2 precision steel shafts Ø 12 mm
- twist-proof
- Aluminum shaft mounting profile, natural anodized
- Attachment from below by using M6 threaded rails in the T-groove and from above by through-holes for M6 inside a grid of 50 mm
- Conditionally self-supporting
- Special lengths offered upon request
- Weight: approx. 2.9 kg/m

Order key

220001 XXXX
 for example 0300 = L 296
 3000 = L 2996
 Length in mm (inside a grid of 100mm)

Profile length = total length L -4 mm
 Special lengths over 3000 mm equipped with rod connection upon request.

Linear guide slide

- Ground steel plate
- Lubrication option
- Clearance-free adjustment possible

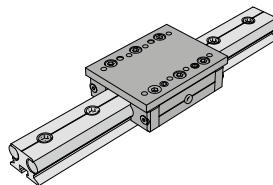

WS 8/70

- L 100 x W 75 x H 31.5 mm
 - Weight: approx. 0.7 kg
- Part No.: 223108 0070

WS 8

- L 150 x W 75 x H 31.5 mm
 - Weight: approx. 1.0 kg
- Part No.: 223108

Carriage

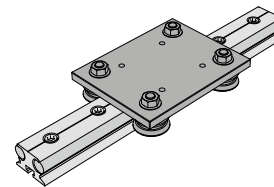

LW 4

- L 125 x W 97 x H 7.7 mm
 - Ground steel plate
 - 4 rollers Ø 31 mm, lubricated over the entire service life
 - Clearance-free adjustment possible
 - Weight: 1.02 kg
- Part No.: 223009

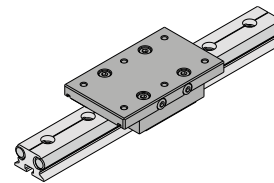

Double track set 1

- L 75 x W 75 x H 30.2 mm
 - Equipped with 2 linear ball bearings SMALL
- Part No.: 223001

Double track set 2

- L 125 x W 75 x H 30.2 mm
 - Equipped with 2 linear ball bearings LARGE
- Part No.: 223002

Deflection

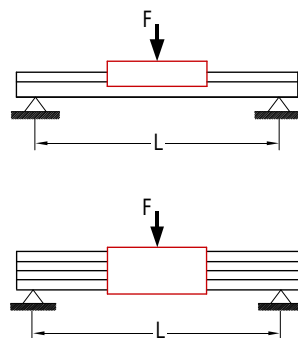
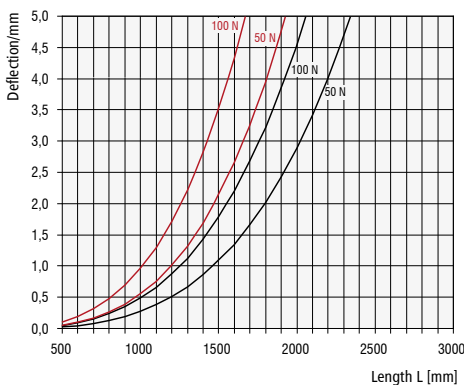



Dimensional drawing

LFS-12-10 equipped with slide type WS 8

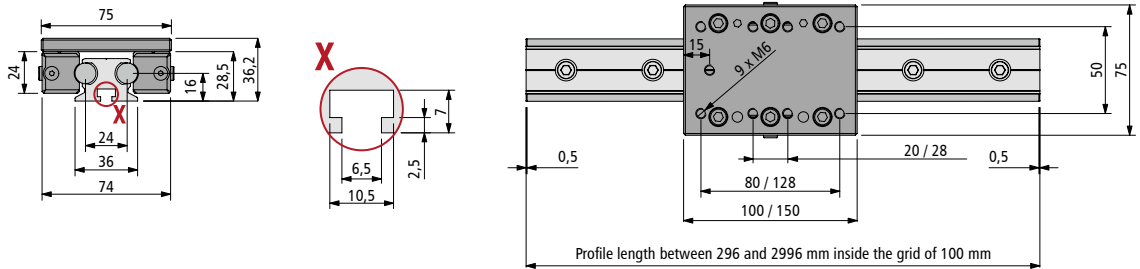

LFS-12-10 equipped with carriage type LW 4

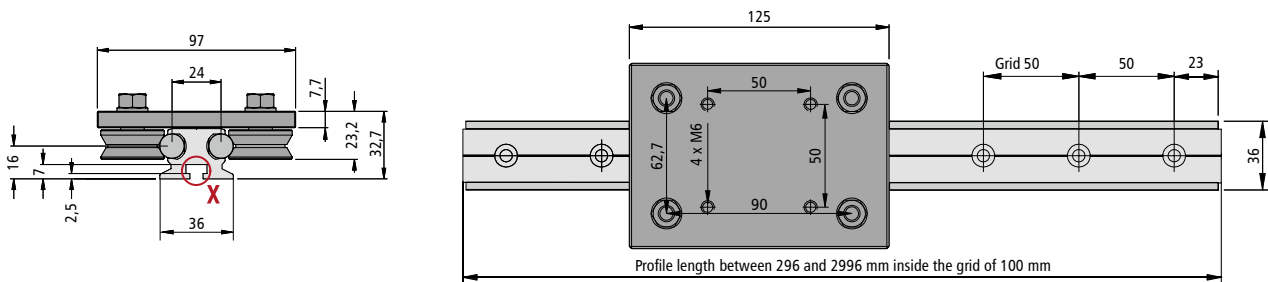

LFS-12-10 equipped with double track set

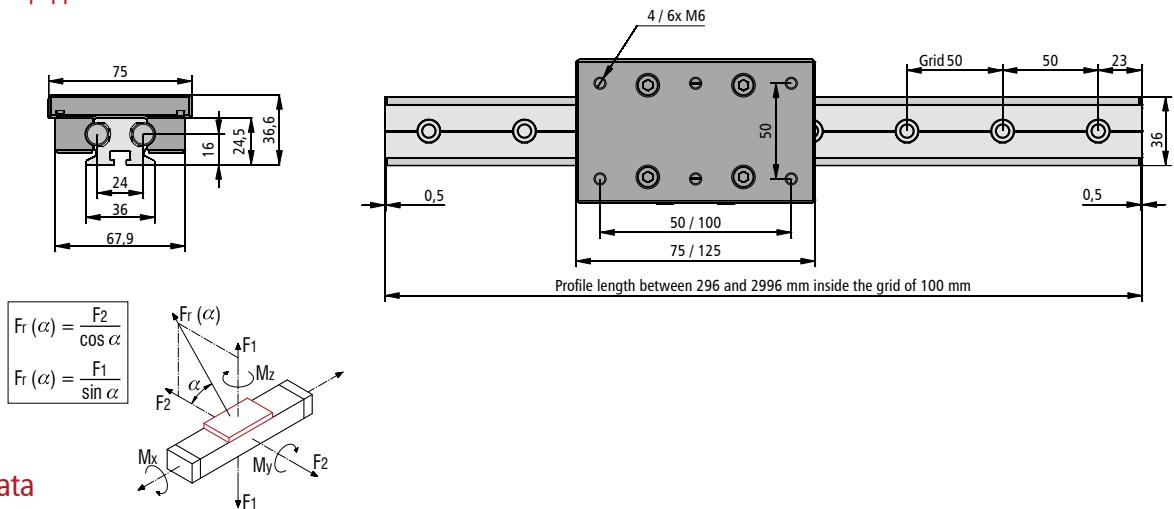

Load data

Linear guide slide type WS 8/70		Linear guide slide type WS 8		Carriage type LW 4		Double track set 1		2	
C ₀	3303 N	C ₀	4868 N	C ₀	2160 N	C ₀	645 N	1905 N	
C	1873 N	C	2426 N	C	4000 N	C	600 N	1125 N	
F ₁ static	2821 N	F ₁ stat.	4157 N	F ₁ stat.	4320 N	F ₁ stat.	652 N	1927 N	
F ₁ dynamic	1599 N	F ₁ dyn.	2071 N	F ₁ dyn.	3846 N	F ₁ dyn.	607 N	1138 N	
F ₂ static	3303 N	F ₂ stat.	4868 N	F ₂ stat.	2160 N	F ₂ stat.	645 N	1905 N	
F ₂ dynamic	1873 N	F ₂ dyn.	2426 N	F ₂ dyn.	4000 N	F ₂ dyn.	600 N	1125 N	
M _x static	46.7 Nm	M _x stat.	68.8 Nm	M _x stat.	135.4 Nm	M _x stat.	16.0 Nm	46.0 Nm	
M _y static	105.3 Nm	M _y stat.	155.2 Nm	M _y stat.	194.4 Nm	M _y stat.	13.0 Nm	119 Nm	
M _z static	123.3 Nm	M _z stat.	181.7 Nm	M _z stat.	97.2 Nm	M _z stat.	13.0 Nm	118 Nm	
M _x dynamic	26.4 Nm	M _x dyn.	34.2 Nm	M _x dyn.	120.5 Nm	M _x dyn.	15.0 Nm	27.0 Nm	
M _y dynamic	59.7 Nm	M _y dyn.	77.3 Nm	M _y dyn.	173.0 Nm	M _y dyn.	12.0 Nm	71.0 Nm	
M _z dynamic	69.9 Nm	M _z dyn.	90.5 Nm	M _z dyn.	180.0 Nm	M _z dyn.	12.0 Nm	70.0 Nm	



T-slot accessories

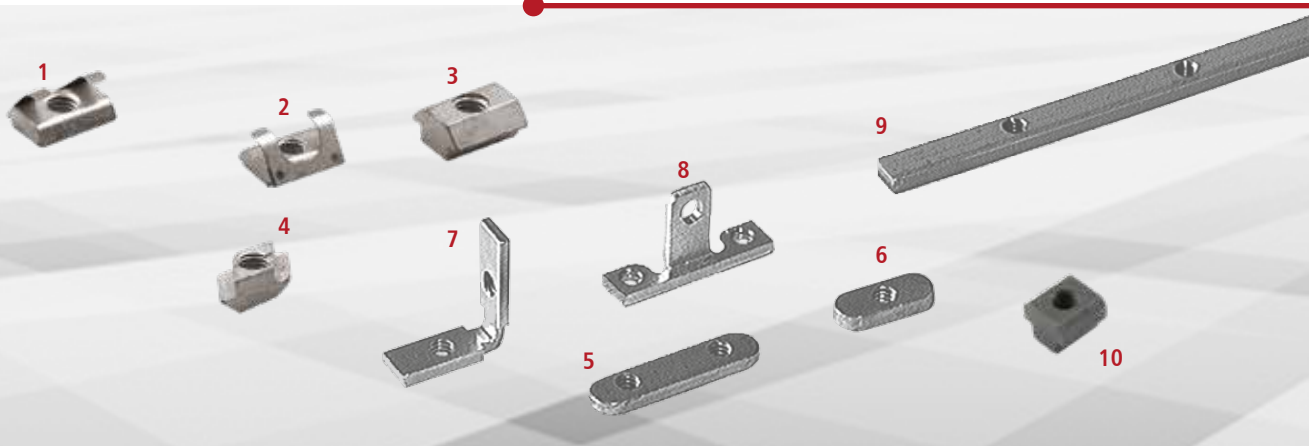

Sliding nuts M5

- galvanized
- PU 20 pieces
- for all T-slots except aluminum profiles: PT 25, PT 50, PS 200, RE 40 and RE 65 (with fastening only possible at the top)

Equipped with spring

Part No. M5: 209005 0002 (figure 2)

Part No. M6: 209005 0003 (figure 1)

with a large bevel

Part No. M6: 209005 0004 (figure 3)

in rhombus shape

Part No. M6: 209005 0006 (figure 4)

Threaded rail M6

- 10 x 4 mm
 - galvanized
 - M6 Ra 50 mm
 - PU 3 pieces per 1 m
- Part No.: 209011 (figure 9)

Sliding nut M6

- L 25 x W 10 x H 3.5
- galvanized
- PU 100 pieces
- For all T-slots except aluminum profiles: PT / RE 40, 65

Part No.: 209001 0005 (figure 6)

Sliding nut M6

- L 25 x W 13 x H 5
- galvanized
- PU 50 pieces
- for all T-slots: PT / RE 40, 65

Part No.: 209004 0001 (figure 6)

Sliding nut 2 x M6

- L 45 x W 10 x H 3.5
- galvanized
- PU 50 pieces
- For all T-slots except aluminum profiles: PT / RE 40, 65

Part No.: 209002 0004 (figure 5)

Sliding nut 2 x M6

- L 45 x W 13 x H 6
- galvanized
- 2 x M6 Ra 25 mm
- PU 25 pieces
- for all T-slots: PT / RE 40, 65

Part No.: 209005 0001 (figure 5)

Angle sliding nut 2 x M6

- galvanized
- PU 25 pieces
- For all T-slots except aluminum profiles: PT / RE 40, 65

Part No.: 209021 0003 (figure 7)

Special angular sliding nut 3 x M6

- galvanized, PU 25 pieces
- For all T-slots except aluminum profiles: PT / RE 40, 65

Part No.: 209022 0003 (figure 8)

T-nuts M6

- DIN 508
- Strength 10
- PU 20 pieces

Part No.: 209119 0003 (figure 10)

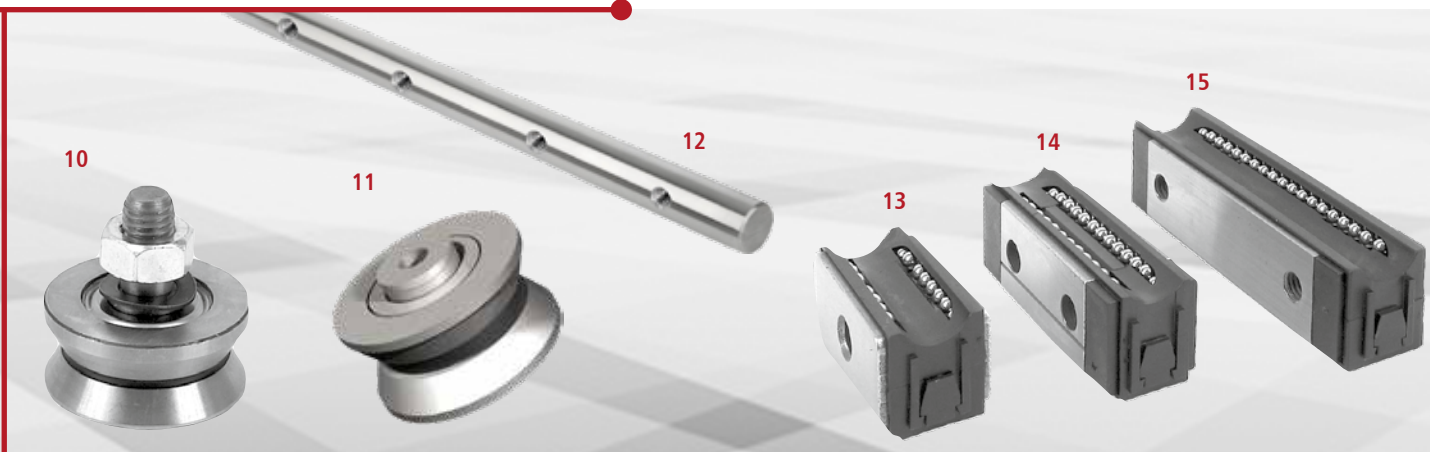

Roller Ø 21 mm

- concentric
- PU 2 pieces

Part No.: 222003 (figure 10)

- eccentric
- PU 2 pieces

Part No.: 222004 (without figure)

Roller Ø 31 mm

- concentric
- PU 2 pieces

Part No.: 222006 (without figure)

- eccentric
- PU 2 pieces

Part No.: 222007 (without figure)

Roller Ø 20 mm for SF 12

- with threaded hole M4
- PU 2 pieces

Part No.: 222010 (figure 11)

Guide shaft SF 12 / SF 16

- Precision steel shaft
Ø 12 and/or 16 mm, length 3 m
- Hardened and ground

Part No.: 220019 XXXX (figure 12)

(SF12, 3m, with blind hole M5 inside the grid of 100 mm)

Part No.: 220020 XXXX (without figure)

(SF12, 3m, with stepped bore for special screws M4 inside the grid of 100 mm)

Part No.: 220023 XXXX (without figure)

(SF16, 3m, with stepped bore for special screws M5 inside the grid of 50 mm)

Part No.: 220024 XXXX (without figure)

(SF16, 3m, with blind hole M6 in the grid of 100 mm)

Linear ball bearing (for steel shafts Ø 12 mm)

Linear ball bearing small

- L 40 x W 20 x H 19 mm
- PU 2 pieces

Part No.: 222001 (figure 13)

Linear ball bearing medium

- L 60 x W 20.5 x H 17.8 mm
- PU 2 pieces

Part No.: 222000 (figure 14)

Linear ball bearing large

- L 80 x W 20 x H 19 mm
- PU 2 pieces

Part No.: 222002 0001 (figure 15)

Universal grease

Part No.: 299031 (without figure)

Impact gun for grease

Part No.: 931170 (without figure)



Profile rail guide type PSF 15, 20, 25 and 30



Features

- High rigidity
- Excellent dynamic characteristics: $V_{max} > 10 \text{ m/s}$, $a_{max} > 450 \text{ m/s}^2$
- High static and dynamic moment loads possible
- the same load ratings for all load directions.
- The guide rails can be screwed on from above (screw head countersink) and from below (thread)
- special surface coatings are possible

Frame size	Lo [mm]	Hc [mm]
PSF 15	12.4	9.35
PSF 20	16.4	12.5
PSF 25	19.5	14.5
PSF 30	24.0	17.0

PSF – profile rail guide

The PSF linear guides are designed with four raceways in an O arrangement. The precision steel balls transmit forces introduced at a contact angle of 45 degrees (see the sketch here in the following). The O arrangement provides a high level of torsional rigidity.

In order to achieve an ideal level in terms of load ratings and rigidity, the greatest possible number of steel balls were used despite the limited space availability. This means that high static and dynamic moment loads are feasible. The same load ratings apply to all load directions with a compact design.

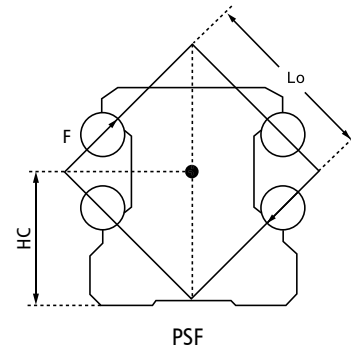

Ecological lubrication system (Eco-System):

The embedded lubrication reservoir supplies the rolling elements directly with the lubricant. This function allows the lubrication intervals to be extended in a considerable manner. The Eco-System is particularly effective for the short-stroke use.

More information concerning the designs, dimensions and ordering options can be found in the PSF linear guides catalogue as well as in the online shop on the website www.isel.com.

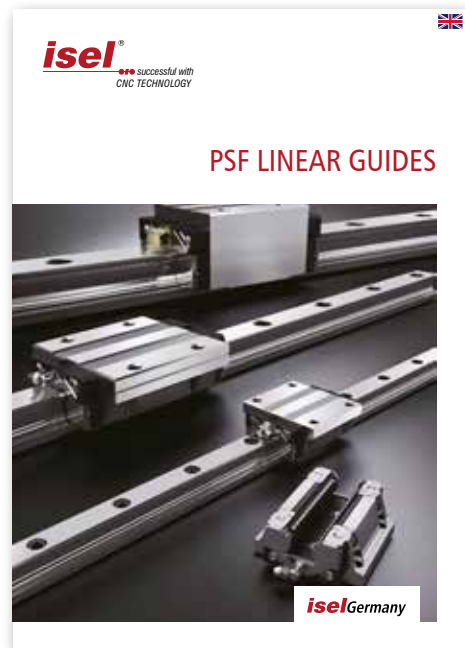



Manual clamping element

Note:

Can be used for ball guide rails.

Assembly note:

Operating temperature range between 0 and 70 °C

Pay attention to a rigid connection construction.



Dimensional drawing

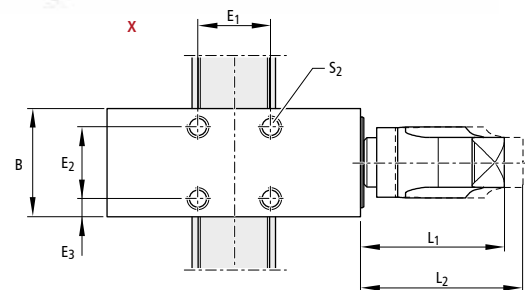
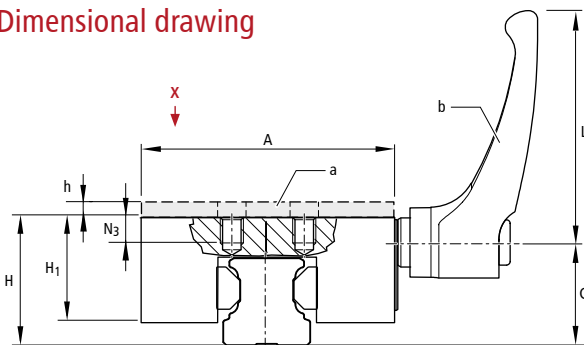

- a) Spacer plate (accessories)
- b) The position of the hand lever can be changed.

Size	Dimensions [mm]											Weight [kg]			
	A	B	C	E ₁	E ₂	E ₃	H ³⁾	H ₁	h	L	L ₁		L ₂ ²⁾	N ₃	S ₂
15	37	24	19.5	17	17	3.5	24	19	4	44	33	30	5	M4	0.1
20	60	24	24.5	15	15	4.5	28	23	2	44	33	30	6	M5	0.2
25	68	28	28	20	20	4	33	26	3 / 7	64	38	41	8	M6	0.28
30	70	39	34	22	22	8.5	42	33	3	64	38	41.5	8	M6	0.64

- 1) Test carried out with oily guide rail
- 2) Manual lever disengaged
- 3) Height compensation by means of a spacer plate (h) depending on the carriage height

Item designation	Size	Holding strength [N]	Tightening Torque [Nm]	Part No.
HKE 15	15	1,200	4	223509 0001
HKE 20	20	1200	5	223510 0001
HKE 25	25	1200	7	223511 0001
HKE 30	30	2,000	12	223512 0001



Linear guides for mechanical engineering

The linear guide is a central element in linear technology, which is characterized by precise design and reliable performance.

www.isel.com/automatisierung/antriebstechnik/linearfuehrungen



Further publications

Media are available in our download area, software and regular updates are available.

www.isel.com/service/download



Optimally networked

Find out more about our branches and cooperation with selected partners.

www.isel.com/unternehmen/partner

isel Germany GmbH

Bürgermeister-Ebert-Straße 40

D-36124 Eichenzell

Tel: +49 (0) 66 59/981-700

E-Mail: info@isel.com

www.isel.com