



advanced
mechatronics



Spindle Motors

incl. accessories

iselGermany

***isel*Germany**

engineering to the point.



isel Germany is part of the stocklisted company Aalberts since february 2022. Since the inception in 1975, Aalberts is where technology matters and real progress can be made - humanly, financially and environmentally.

Greatness is made of shared knowledge

Just like isel Germany, all Aalberts companies stand their ground in the engineering and technology world. As the world is changing rapidly and innovation cycles are reduced dramatically, the open and pragmatic internal culture at Aalberts helps us to exchange fresh thinking and to embrace new technologies.

Content

Around the spindle	4
The isel locations	4
Contact, advice and support	5
Overview spindle motors	6

ISA spindle motors

iSA 750	8
iSA 900 W	10
iSA 1200 W	12
iSA 1500	14
iSA 2200 W	16

Milling spindels

ES 325 HSK 25	18
ES 950 SK 30	20
iFM 1000 ER	22
iFM 1000 WS	23

Accessories

Linear tool change station	24
Frequency converter	25
Collets and device	26
Cutter Box & Length measuring pushbutton	27
CoolMin® – Tool and material cooling	28
Dust extraction systems	30
Dust extraction devices	32
Minimum volume coolant misting system	33

Around the spindle

During the development of our spindle motors, great emphasis was placed above all on functionality, quality and optimum pricing. In addition, our spindle motors are particularly durable. Due to the particularly slim design and the square housing cross-section, series arrangements with minimum distances can be realized.

As far as the electrical design is concerned, our motors are three-phase squirrel-cage rotors with 2-pole windings, designed in accordance with DIN EN 60034. The insulating materials of the windings are manufactured in accordance with thermal class F. The motors are dynamically precision-wound. The motors are dynamically finely balanced, so that good running characteristics are achieved even at high speeds. They cover a total speed range from 1,000 to 50,000 rpm.

All spindle motors are completely manufactured in Europe, meet at least the requirements of protection class IP54 and are thus also approved for the wood dust area.

In our offer you will find not only the spindle motors themselves, but also all necessary cables in different lengths and preset, reliable frequency converters for the control connection. The programming of these frequency converters is handled by isel, as is the tuning of all pneumatic parts, which simplifies commissioning for the customer and thus saves time.

By integrating development, production, sales and service under one roof, we have very short distances compared to many of our competitors and have our own year-round repair service.

The iSA spindle motors are air-cooled with an integrated fan. This allows easy installation for quick use of the milling spindle in your CNC system.

Extensive accessories such as dust extraction, minimum quantity lubrication technology, collets, SK holders, tool changers and our unique, patented CoolMin system for optimal and economical tool cooling without residues complete our product range.

Do you have questions about our spindles?

Then contact our technical sales department. They will give you information about the individual spindle motors including accessories and will prepare your personal offer on request!



Plant in Eichenzell

36124 Eichenzell, Hesse
Total area: approx. 30,000 m²

Contact | Advice | Support

isel Germany GmbH
Bürgermeister-Ebert-Straße 40
D-36124 Eichenzell

Phone: +49 (0) 6659 / 981-700
Fax: +49 (0) 6659 / 981-776
info@isel.com

Sales, order processing and head office

Mon to Thu 7:30 a.m. - 4:30 p.m.
Friday 7:30 a.m. - 2:00 p.m.

Dispatch and incoming goods

Mon to Thu 7:00 a.m. - 3:00 p.m.
Friday 7:00 a.m. - 12:30 p.m.

Self-collector

Mon to Thu 8:00 a.m. - 1:00 p.m.
Friday 8:00 a.m. - 11:00 a.m.

Customer Support

Phone: +49 (0) 6659 / 981-800
Fax: +49 (0) 6659 / 981-570
support@isel.com

Application technique

Phone: +49 (0) 6659 / 981-790
Fax: +49 (0) 6659 / 981-776
anwendungstechnik@isel.com

Sales team



Stefan Koch
Head of Operations
CNC systems

Phone: +49 (0) 6659 / 981-526
Fax: +49 (0) 6659 / 981-777
stefan.koch@isel.com



Jürgen Balzer
Technical sales
CNC systems

Phone: +49 (0) 6659 / 981-774
Fax: +49 (0) 6659 / 981-776
juergen.balzer@isel.com



Katja Henkel
Technical sales
Automation

Phone: +49 (0) 6659 / 981-744
Fax: +49 (0) 6659 / 981-777
katja.henkel@isel.com



Steffan Gärth
Technical sales
Automation

Phone: +49 (0) 6659 / 981-773
Fax: +49 (0) 6659 / 981-776
steffan.gaerth@isel.com



Jessica Gatterdam
Team assistant

Phone: +49 (0) 6659 / 981-751
Fax: +49 (0) 6659 / 981-776
jessica.gatterdam@isel.com

iSA Spindle motors with manual tool changer



iSA 750

- rated output 0.75 kW
 - speed range 3,000 rpm – 28,000 rpm
- page 8



iSA 1500

- rated output 1.5 kW
 - speed range 5,000 rpm – 20,000 rpm
- page 14

iSA Spindle motors with automatic tool changer



iSA 900 W

- rated output 0.9 kW
 - speed range 6,000 U/min – 24,000 U/min
- auf Seite 10



iSA 1200 W

- rated output 1.2 kW
 - speed range 5,000 rpm – 22,000 rpm
- page 12



iSA 2200 W

- rated output 2.2 kW
 - speed range 5.000 rpm – 20.000 rpm
- page 16

Milling spindels



ES 325 HSK 25

- rated output 2.0 kW
 - speed range 6,000 rpm – 40,000 rpm
- page 18



ES 950 SK 30

- rated output 3.8 kW
 - speed range 12,000 rpm – 24,000 rpm
- page 20



iFM 1000 ER

iFM 1000 WS

- speed range 4,000 rpm – 25,000 rpm
on page 22 and 23

Milling spindles of various manufacturers



After detailed technical examination also spindle motors in the power range 0.5 kW to 6.5 kW from various manufacturers can be integrated.

For more information, please contact your competent sales partner.

Spindle motor iSA 750



iSA 750 | Spindle motor with manual tool changer

- robust 2-pole AC motor (asynchronous motor)
- square shape
- protection class IP54, insulation class F
- M23 plug connection
- A side: aluminium extrusion / B side: cast iron end shield
- motor shaft to take ER 16 collets
- incl. ER 16 collet, Ø 6 mm
- clamping range Ø 1 mm – Ø 10 mm
- intrinsic ventilation B-side
- two precision bearings
- controlled by frequency converter
- fitting holes Ø 5 mm (±0.1) for easy spindle replacement

Technical specification

Torque [Nm] (at rated speed 22,000 rpm)	0.34
Speed range [U/min.]	3,000 – 28,000
Cut-off frequency* [Hz] / Speed [U/min.]	300 / 18,000
Number of poles	2
Rated voltage [V]	220 (star connection)
Rated current [A]	3.4
Power factor (cos φ)	0.79
Rated power [kW] (S6 = 40% Operation)	0.75
Concentricity [mm]	0.01
Weight [kg]	2.6

*cut-off frequency = frequency to which the motor effect is designed.

Options

- CoolMin® (internal and external)
- frequency converter SKC 750
- various collets ER 16
- connection cable in different lengths
- suction device
- mounting plates
- sealing air connection



iSA 750
with CoolMin® internal

Torque curves

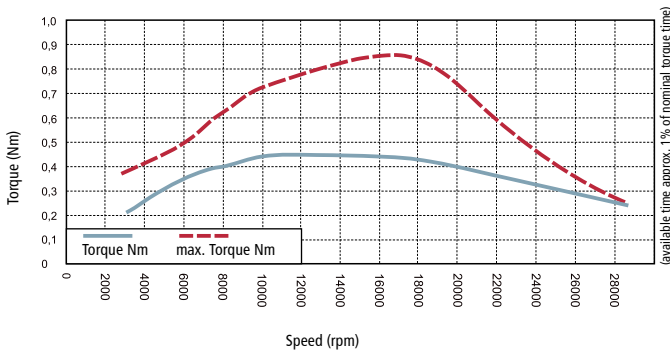

Motor connection

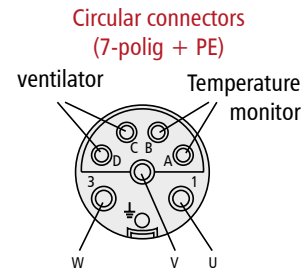

Dimensional drawing

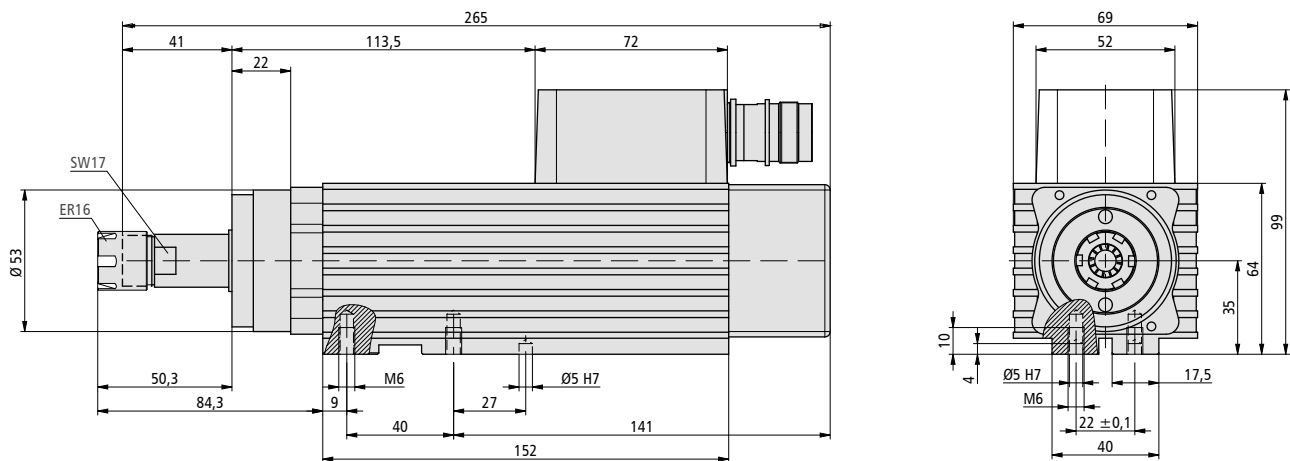

Order data

		Part No.
Spindle motor iSA 750	with collet ER 16 (6 mm)	477008 3124
	with converter** and connecting cable (8 m), incl. collet ER 16 (6 mm)	310708 1611
	with CoolMin® (internal), incl. collet ER 16 (6 mm)	477008 5124
	with converter**, connecting cable (8 m) and CoolMin®, incl. collet ER 16 (6 mm)	310707 1631
CoolMin®	external	239011 0119
Frequency converter	SKC 750	311707 6000
Collet set	ER 16 / clamping range 1.0 - 10.0 mm (for individual collets see page 26)	239171 0001
Suction device	for EuroMod / FlatCom (prepared for Ø 38 mm hose)	239012 0000
	for ICP / ICV 4030 (prepared for Ø 21 mm hose, with cold air nozzle)	280211 9001
Suction head	AK 750 for CoolMin® (prepared for Ø 38 mm hose)	239012 0012
Mounting plates isel systems (Z axis)	Mounting plate set on LES 5	675015 9297
	Mounting plate set on LES 6	675015 9298

**converter pre-set for spindle



Spindle motor iSA 900 W



iSA 900 W | Spindle motor with automatic tool changer

- robust 2-pole three-phase motor (asynchronous motor)
- rectangular design
- protection class IP55, insulation class F
- motor plug connection M23
- cast bearing shield A and B side
- pneumatic tool change SK 11 (7.5 bar)
- including collet chuck ER 11, Ø 3 mm
- clamping range Ø 1 mm - Ø 7 mm
- forced cooling fan on B side
- double precision bearing
- speed control via frequency inverter
- fitting holes Ø 5 mm (±0.1) for easy spindle replacement

Technical data

Torque [Nm] (at nominal speed 22,000 rpm)	0.37
Speed range [rpm].	6,000 – 24,000
Cut-off frequency* [Hz] / speed [rpm].	400 / 24,000
Number of motor poles	2
Nominal voltage [V]	230 (star connection)
Rated current [A]	3.25
Power factor (cos φ)	0.84
Nominal power [kW] (S6 = 40% operation)	0.9
Concentricity [mm]	0.01
Weight [kg]	5.8

*Base frequency = frequency to which the motor action is designed.

The iSA 900 W spindle motor is only suitable for light aluminum, wood and plastic processing.

Options

- Sensor module
- CoolMin® (external)
- SKC 750 frequency inverter
- Tool changing station
- Various ER 11 collets
- Connection cable in various lengths
- Suction device
- Mounting plates
- Air purge connection

Spindle motor iSA 1200 W



iSA 1200 W | Spindle motor with automatic tool changer

- robust 2-pole AC motor (asynchronous motor)
- square shape
- protection class IP55, insulation class F
- M23 plug connection
- cast end shield A and B sides
- tool change SK 16 pneumatic (7,5 bar)
- incl. ER 16 collet, Ø 6 mm
- clamping range Ø 3 mm – Ø 10 mm
- intrinsic ventilation B-side
- two precision bearings
- controlled by frequency converter

Options

- CoolMin® (external)
- frequency converter SKC 750
- tool changing station
- various collets ER 16
- connection cable in different lengths
- suction device
- mounting plates
- sealing air connection

Technical specification

Torque [Nm] (at rated speed 22,000 rpm)	0.5
Speed range [U/min.]	5,000 – 22,000
Cut-off frequency* [Hz] / Speed [U/min.]	300 / 18,000
Number of poles	2
Rated voltage [V]	230 (star connection)
Rated current [A]	4.5
Power factor (cos φ)	0.84
Rated power [kW] (S6 = 40% Operation)	1.2
Concentricity [mm]	0.01
Weight [kg]	7

*cut-off frequency = frequency to which the motor effect is designed.

The spindle motor iSA 1200 W is suitable to process light to medium duty work such as Aluminum, wood and plastic.

The light weighted and compact spindle design is perfect for CNC table machines ICV.

Torque curves

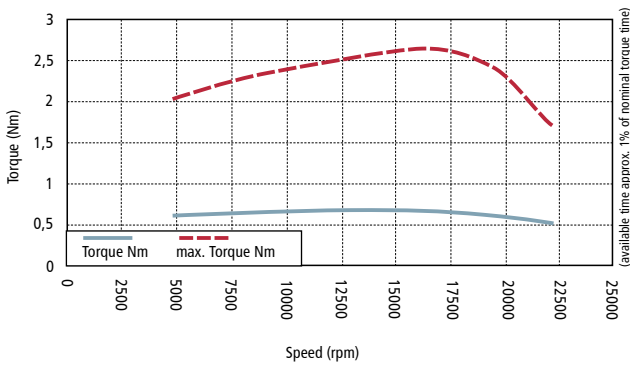

Motor connection

Circular connectors
(M23: 7-polig + PE)

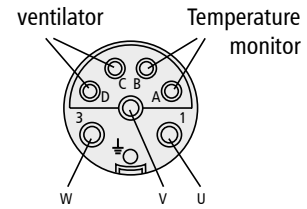

Sensor connector tool changer
(M8: 6-pole)

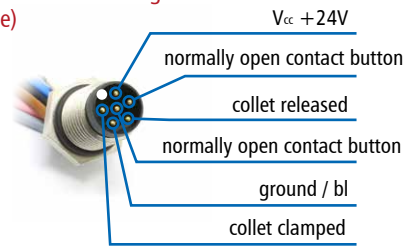

Dimensional drawing

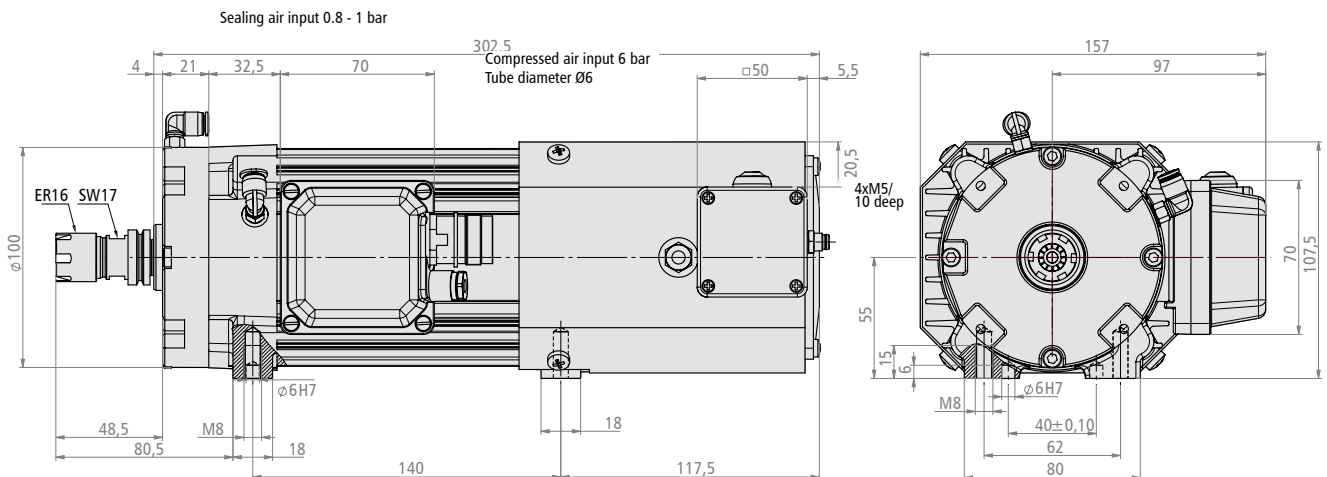

Order data

Order data		Part No.
Spindle motor iSA 1200 W	with collet ER 16 (6 mm)	477012 3321S
	with converter** and connecting cable (8 m), incl. collet ER 16 (6 mm)	310712 3611S
CoolMin®	external, with articulated hose	239011 0119
Frequency converter	SKC 750	311707 6000
Collet Set	ER 16 / clamping range 1.0 - 10.0 mm (for individual collets see page 26)	239171 0001
Tool change station***	linear SK 16, 4-port	239016 0041
	linear SK 16, 5-port	239016 0051
Tool holder	SK 16 (for collet ER 16)	239116 0001
Suction device****	for automatic tool changers	on request
Suction head	AK 1200 (prepared for Ø 50 mm hose)	239012 SDU6032
Mounting plates isel systems (Z axis)	Mounting plate set on LES 5	675015 9301
	Mounting plate set on LES 6	675015 9302

converter pre-set for spindle *special changing stations on request ****not compatible with tool change station at ICP and ICV



Spindle motor iSA 1500



iSA 1500 | Spindle motor with manual tool changer

- robust 2-pole AC motor (asynchronous motor)
- square shape
- protection class IP54, insulation class F
- M23 plug connection
- cast end shield A and B sides
- motor shaft to take ER 20 collets
- incl. ER 20 collet, Ø 6 mm
- clamping range Ø 1 mm – Ø 13 mm
- intrinsic ventilation B-side
- double precision bearing
- controlled by frequency converter

Technical specification

Torque [Nm] (at rated speed 22,000 rpm)	0.72
Speed range [U/min.]	5.000 – 20,000
Cut-off frequency* [Hz] / Speed [U/min.]	300 / 18,000
Number of poles	2
Rated voltage [V]	200 (star connection)
Rated current [A]	7.0
Power factor (cos φ)	0.85
Rated power [kW] (S1 Operation)	1.5
Concentricity [mm]	0.01
Weight [kg]	6.4

*cut-off frequency = frequency to which the motor effect is designed.

Options

- CoolMin® (internal and external)
- frequency converter SKC 750
- various collets ER 20
- connection cable in different lengths
- suction device
- mounting plates
- sealing air connection



iSA 1500
with CoolMin® internal

Torque curves

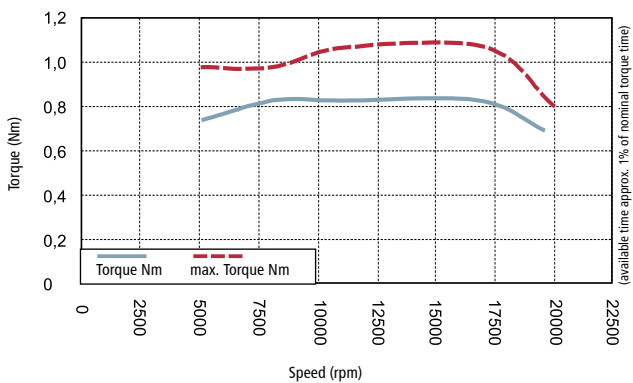

Motor connection

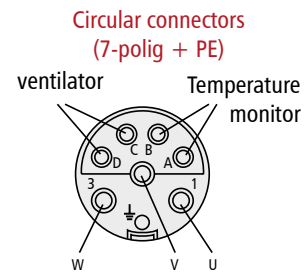

Dimensional drawing

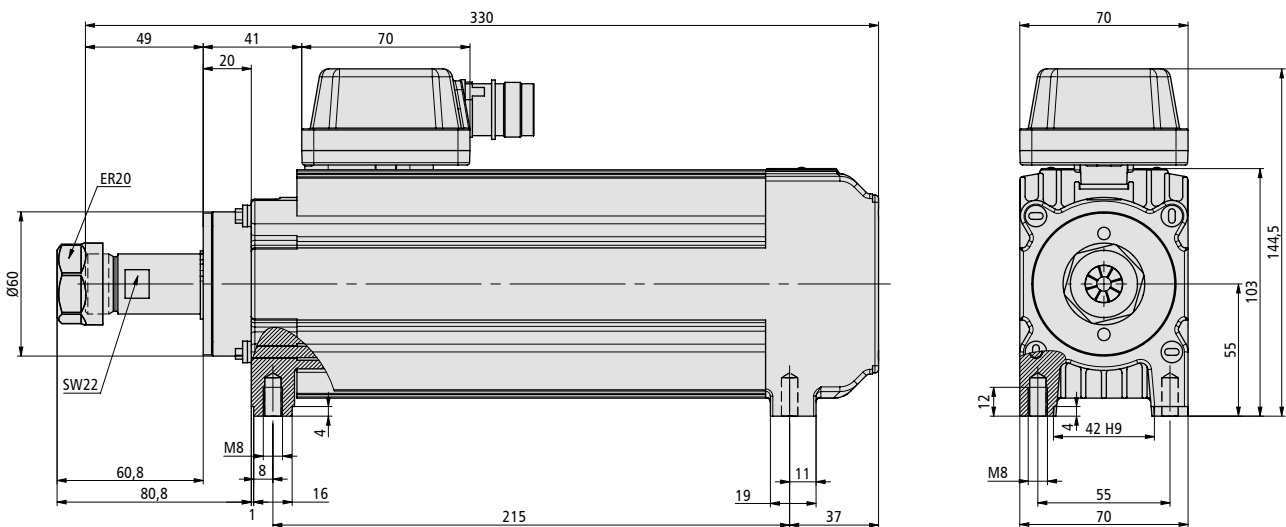

Order data

Order data		Part No.
Spindle motor iSA 1500	with collet ER 20 (6 mm)	477510 3120
	with converter** and connecting cable (8 m), incl. collet ER 20 (6 mm)	310610 3614
	with CoolMin® (internal), incl. collet ER 20 (6 mm)	477510 5120
	with converter** and connecting cable (8 m) and CoolMin®, incl. collet ER 20 (6 mm)	310610 3634
CoolMin®	external	239011 0119
Frequency converter	SKC 1500	311715 6000
Collet Set	ER 20 / clamping range 1.0 - 13.0 mm (for individual collets see page 26)	239172 0001
Suction device	prepared for Ø 80 mm hose, with or without CoolMin®	239012 0001
Suction head	AK 1500 for CoolMin® (prepared for Ø 50 mm hose)	239012 SDU0435
Mounting plates isel systems (Z axis)	Mounting plate set on LES 5	675015 9303
	Mounting plate set on LES 6	675015 9304

**converter pre-set for spindle

Spindle motor iSA 2200 W



iSA 2200 W | Spindle motor with automatic tool changer

- robust 2-pole AC motor (asynchronous motor)
- square shape
- protection class IP 55, insulation class F
- M23 plug connection
- cast end shield A and B sides
- tool change SK 20 pneumatic (7,5 bar)
- incl. ER 20 collet, Ø 6 mm
- clamping range Ø 1 mm – Ø 13 mm
- intrinsic ventilation B-side
- two precision bearings
- controlled by frequency converter

Technical specification

Torque [Nm] (at rated speed 22,000 rpm)	1.26
Speed range [U/min.]	5,000 – 20,000
Cut-off frequency* [Hz] / Speed [U/min.]	300 / 18,000
Number of poles	2
Rated voltage [V]	3 x 230 (star connection)
Rated current [A]	7.6
Power factor (cos φ)	0.84
Rated power [kW] (S6 = 40% Operation)	2.2
Concentricity [mm]	0.01
Weight [kg]	14.6

*cut-off frequency = frequency to which the motor effect is designed.

Options

- CoolMin® (external)
- CoolMin® (internal) with internal mold cooling
- frequency converter SKC 1500
- tool changing station
- various collets ER 20
- connection cable in different lengths
- suction device
- mounting plates
- sealing air connection



iSA 2200 W
with CoolMin® internal

Torque curves

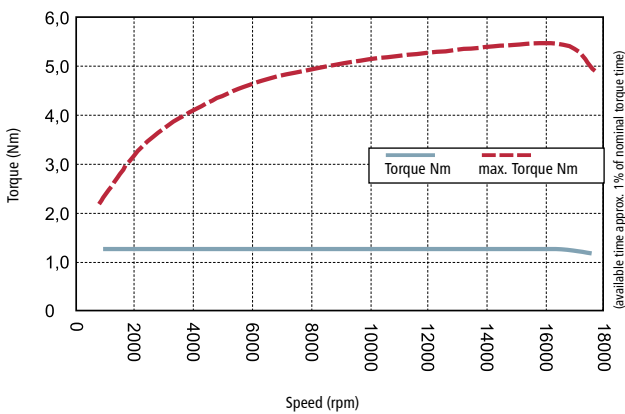

Motor connection

Circular connectors
(M23: 7-polig + PE)

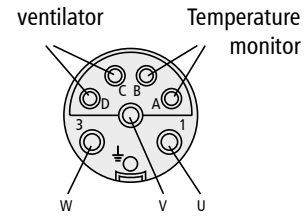

Sensor connector tool changer
(M8: 6-pole)

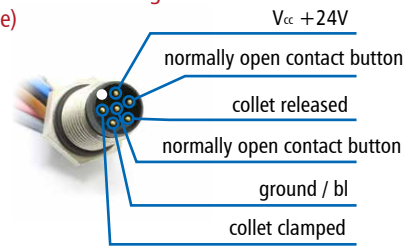

Dimensional drawing

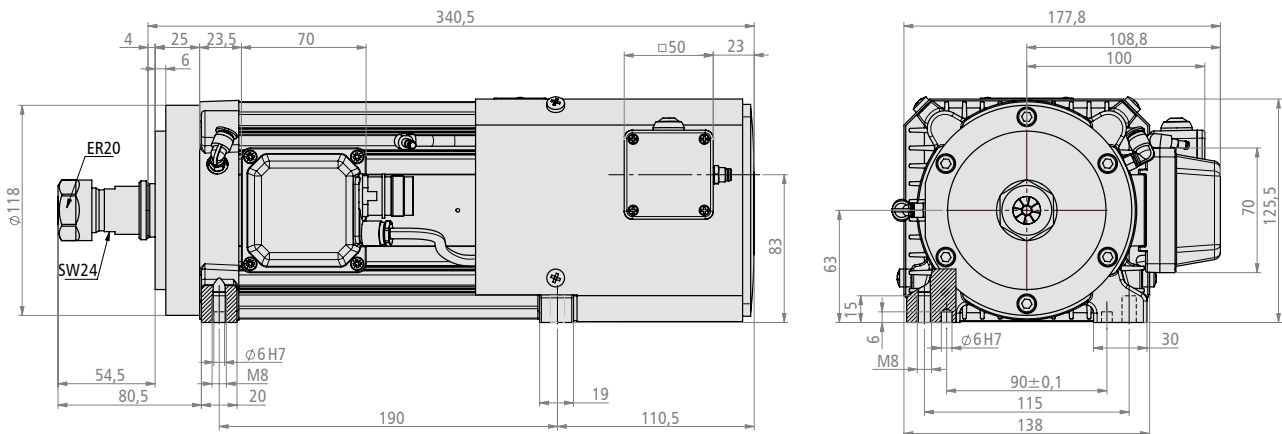

Order data

Part No.

Spindle motor	with collet ER 20 (6 mm)	477022 3319S
iSA 2200 W	with converter** and connecting cable (8 m), incl. collet ER 20 (6 mm)	310722 3620S
	with CoolMin® (internal), incl. collet ER 20 (6 mm)	477022 5319S
	with converter** and connecting cable (8 m) and CoolMin®, incl. collet ER 20 (6 mm)	310722 3630S
CoolMin®	external	239011 0119
Frequency converter	SKC 1500	311715 6000
Collet Set	ER 16 / clamping range 1.0 - 13.0 mm (for individual collets see page 26)	239172 0001
Tool change station***	linear SK 20, 4-port	239011 0041
	linear SK 20, 8-port	239011 0081
Tool holder	SK 20 (for collet ER 20)	239172 0020
Suction device	prepared for Ø 80 mm hose, for automatic tool changers	239012 0002
	prepared for Ø 80 mm hose, for automatic tool changers, with external tool cooling	239012 0003
Suction head	AK 2200 (prepared for Ø 50 mm hose)	239012 SDU2355
Mounting plates (Z axis)	Mounting plate set on LES 5	675015 9350
	Mounting plate set on LES 6	675015 9352

**converter pre-set for spindle

***special changing stations on request

Milling spindle ES 325 HSK 25



Milling spindle ES 325 HSK 25 with pneumatic tool charger

- automatic tool locking with pneumatic piston
- front ceramic bearing
- rear ceramic bearing
- lifetime lubrication
- water cooled max. speed: 40.000 rpm
- spindle housing aluminium alloyed

Technical specification

Rated speed [min ⁻¹]	40,000
Rated voltage [V]	380
Rated current [A]	4.0
max. rated output [kW]	2.0
Weight [kg]	7.0

Optional

- linear tool changer HSK 25
- clamp for HSK 25 and HSK 32
- tool holders
- CoolMin® (external)
- frequency converter SKC 4000
- mounting plates
- different lengths of connecting cable

Torque curves

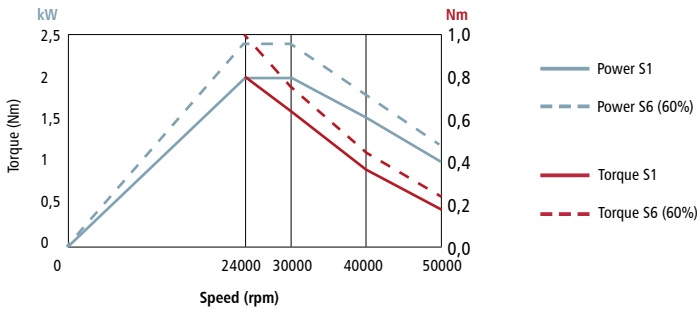

Motor connection

Signals

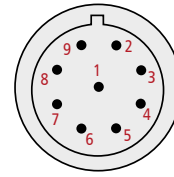

- 2 +24V DC sensor power supply
- 3 0 V sensors
- 4 Output Sensor S1 (tool locked)
- 5 Output Sensor S2 (tool ejected)
- 6 Output Sensor S3 (shaft stopped)

Motor

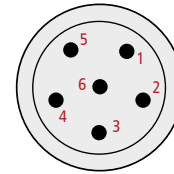

- 1 Motor V phase
- 2 Motor U phase
- 3 Motor W phase
- 4 PE
- 5 Thermal Protection
- 6 Thermal Protection

Dimensioned drawings

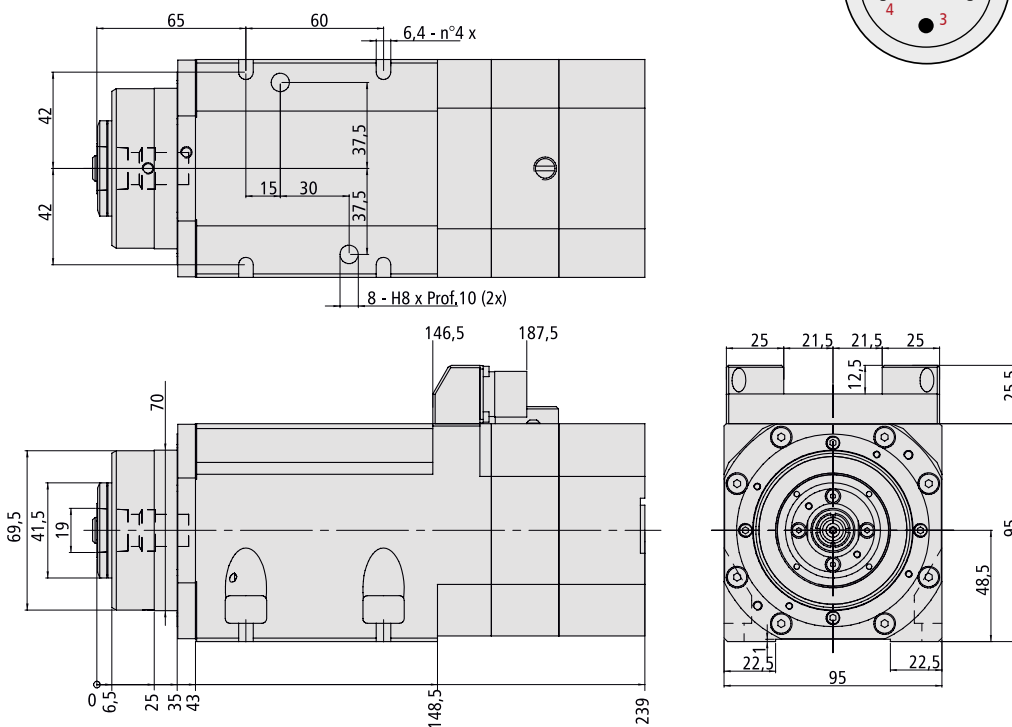

Order data

Part No.

Milling spindle ES 325 HSK 25	basic	478015 1340
	with converter**, maintenance unit and connection line 8 m, Collet EX 16, 6 mm, air or water cooled	310815 3511
Frequency converter	SKC 4000	311740 6500
CoolMin®	external	239011 0119
Tool holder	HSK 25	477125
Collets (on page 26)	in Ø 1,0 / 1,5 / 2,0 / 2,5 / 3,0 / 4,0 / 5,0 / 6,0 / 7,0 / 8,0 / 9,0 / 10,0	477125 80XX
Clamps	for holding HSK 25	639100 0043
Tool change station***	linear changer HSK 25, 5-fold	239011 0051
	linear changer HSK 25, 10-fold	239011 0101
Mounting plate	at linear unit LES 5 and LES 21	277028 0001
Cooling unit 16 S	for milling spindle ES 325	492015 2001
Storage rack	for cooling unit 16 s	274507 6300

**converter pre-set for spindle

***Special change stations on request

Milling spindle ES 950 SK 30

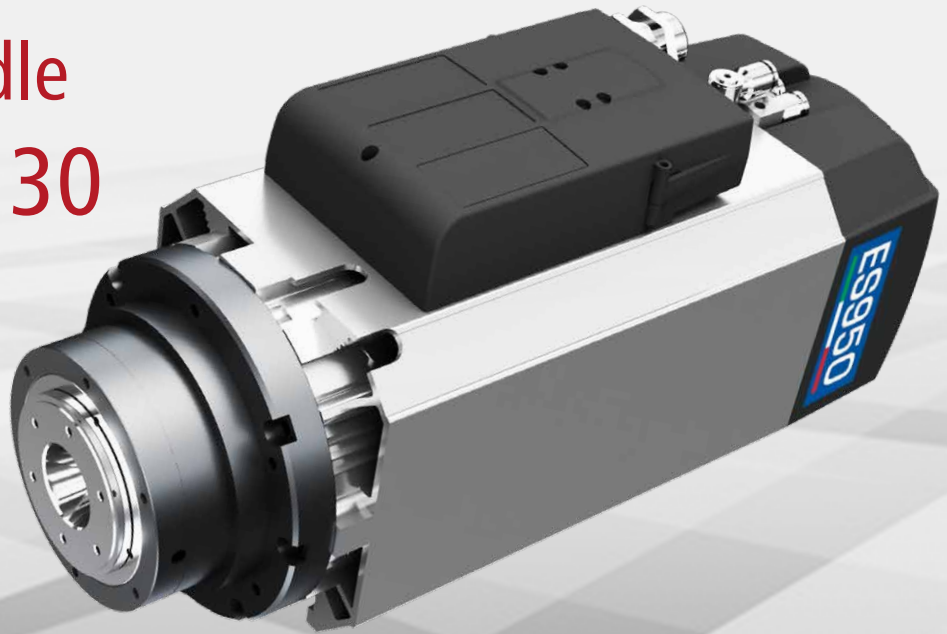

ES 950 SK 30 milling spindle with automatic tool changer

- automatic tool locking with pneumatic piston (release piston)
- front bearing ceramic
- rear bearing ceramic
- bearing lubrication Lubricated for life
- air-cooled max. speed up to 24,000 rpm.
- spindle housing aluminum alloyed

Optional

- Linear changer SK 30
- Retaining clips SK 30
- Tool holders
- CoolMin (extern)
- SKC 4000 frequency inverter
- Mounting plates
- Connection cable in various lengths

Technical specification

Nominal voltage [V]	380		380		220		220	
Nominal frequency [Hz]	200		400		200		400	
Rated speed [rpm]	12000		24000		12000		24000	
Operating mode	S1 Continuous operation	S6 60%	S1 Continuous operation	S6 60%	S1 Continuous operation	S6 60%	S1 Continuous operation	S6 60%
Rated power [kW]	3,8	4,5	3,8	4,5	3,8	4,5	3,8	4,5
Nominal torque [Nm]	3	3,6	1,5	1,8	3	3,6	1,5	1,8
Rated current [A]	8,5	10,2	8	9,6	14,7	17,7	14	16,8
Weight [kg]	22,5							

Power curve

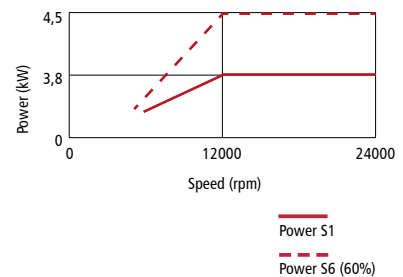

Motor connection

Power connector

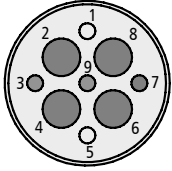

- 1 Not used
- 2 GROUND in common with PIN7
- 3 +24V DC Electric fan (1A max)
- 4 U Motor Phase
- 5 Not used
- 6 V Motor Phase
- 7 Shield power cable in common with PIN2
- 8 W Motor Phase
- 9 0V DC Electric fan

Signals connector

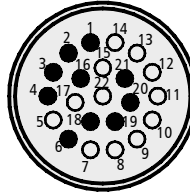

- 1 OUTPUT S2 (tool unlocked)
- 2 OUTPUT S1 + S4 + S5 (tool locked)
- 3 OUTPUT S3 (spindle rotation)
- 4 +24V DC sensors (1A max)
- 6 0V DC sensors
- 16 Shield
- 18 Electric fan
- 19 ELECTRONICS WORKING
- 20 OUTPUT no tool
- 21 Motor thermal alarm (0/24V DC)

Dimensioned drawings

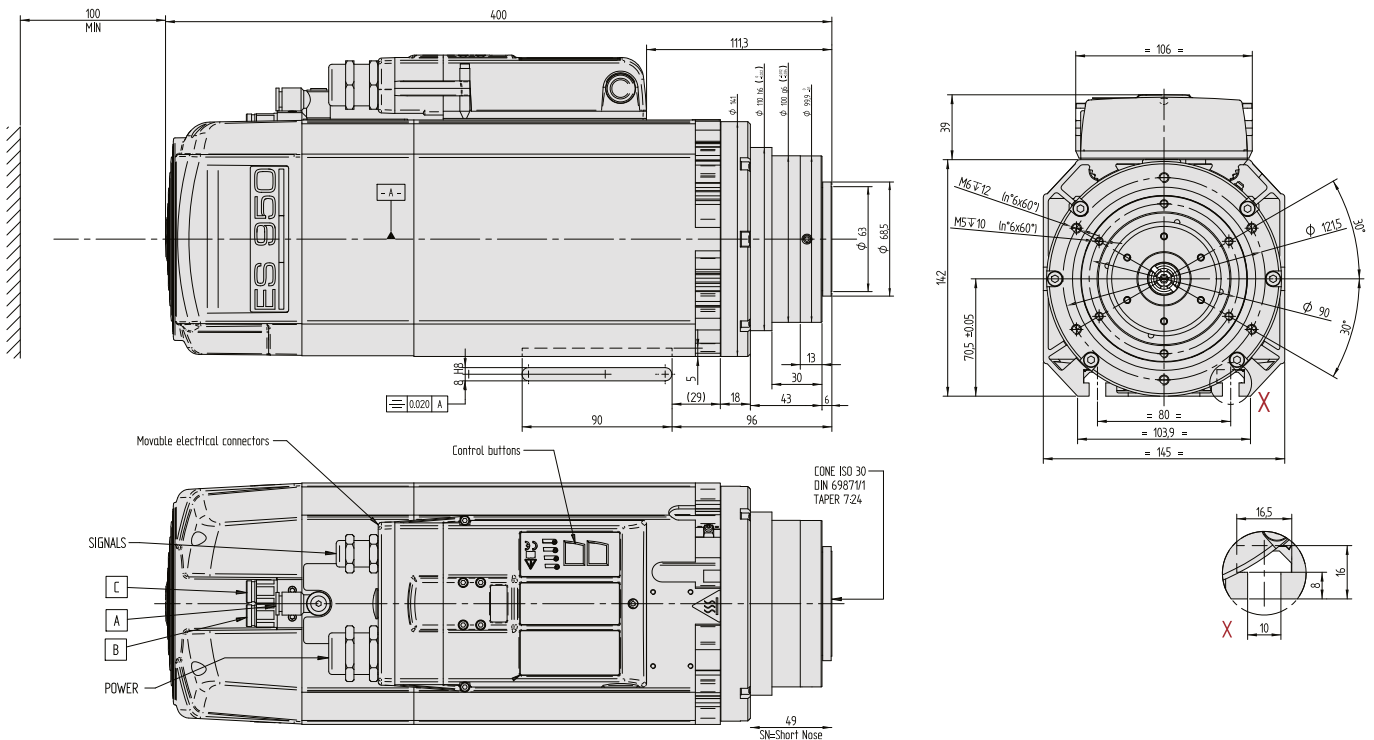

Order data

Part No.

Milling spindle ES 950 SK 30		445000 1919
Milling spindle ES 950 SK 30 with inverter	with connecting cable 10 m, collet ER 32, 6 mm	310815 35140
SKC 4000 frequency inverter		311740 6500F
CoolMin	extern	239011 0119
Tool holder SK 30		445000 1996
Collets (on page 26)	ER 32 / clamping range 3.0 - 20.0 mm (for individual collets see page 26)	239130 0000
Linear changer	4-fold	239011 0045
	5-fold	239011 0055
	10-fold	239011 0105
Clamping claw SK 30		639100 4559

Milling motor iFM 1000 ER



iFM 1000 ER | Milling motor

- extremely quiet
- spindle lock
- external portal interface
- LED indication for overload
- Duo-In: speed can be adjusted manually or via the infinitely variable to suit any application application
- highest concentricity due to the filigree coordination of all components
- digital electronics with soft start, constant speed under load, idle speed reduction and overload protection

Technical data

Nominal power consumption [W]	1,000
Universal motor [V / Hz]	230 / 50
Nominal idling speed [rpm]	4,000 – 25,000
Portal connection	M8 / 4-pol.
Power supply in PV operation [V]	7 - 56
Portal control [V]	0 - 10
Clamping collar / collet [mm]	43 / 8
Dimensions (L x W x H) [mm]	254 x 79 x 73
Sound pressure level [dB (A)]	71
Weight [kg]	1.65

Areas of application:

- model making, mould making, advertising technology, engraving, jewellery, electronics
- for wood, non-ferrous metals, plastics, foam, polystyrene

Ordering data

		Part No.
Milling motor iFM 1000 ER	incl. collet (ER 16, 8 mm), cap nut, hook wrench ER 16 and 0.75 m connection cable	420003 1000
Collets	ER 16, 3 mm	239171 3000
	ER 16, 4 mm	239171 4000
	ER 16, 6 mm	239171 6000
	ER 16, 8 mm	239171 8000
	ER 16, 3,175 mm (1/8")	239171 3175
	ER 16, 6,35 mm (1/4")	239171 0635
PV control cable	M8 / 4-pol, 5 m	420003 1016
Suction head	prepared for hose Ø 50 mm	239012 SDU8950
Clamping block	For mounting on Z-axis (LES 5)	639112 8952

Milling motor iFM 1000 WS



iFM 1000 WS | Milling motor

- extremely quiet
- tool-less quick-clamping device
- external portal interface
- LED indication for overload
- Duo-In: speed can be adjusted manually or via the infinitely variable to suit any application application
- highest concentricity due to the filigree coordination of all components
- spindle with double bearings to absorb axial forces
- digital electronics with soft start, constant speed under load, idle speed reduction and overload protection

Technical data

Nominal power consumption [W]	1,000
Universal motor [V / Hz]	230 / 50 w
Nominal idling speed [rpm]	4,000 – 25,000
Portal connection	M8 / 4-pol.
Power supply in PV operation [V]	7 - 56
Portal control [V]	0 - 10
Portal mounting (holes)	6 x M6
Clamping collar / collet [mm]	43 / 8
Dimensions (L x W x H) [mm]	280 x 92 x 85
Tool holder [mm]	8
Sound pressure level [dB (A)]	71
Weight [kg]	2.8

Areas of application:

- model making, mould making, advertising technology, engraving, jewellery, electronics
- for wood, non-ferrous metals, plastics, foam, polystyrene

Ordering data

		Part No.
Milling motor iFM 1000 WS	incl. 0.75 m connection cable	420003 1001
Adapter sleeve (ground)	3 mm	420003 1018
	1/8" (3.175 mm)	420003 1019
	4 mm	420003 1020
	6 mm	420003 1021
Collet adapter	ER 16 incl. union nut ER 16*	420003 1023
PV-Steuerkabel	M8 / 4-pol, 5 m	420003 1016
Suction head	prepared for hose Ø 50 mm	239012 SDU9459
Clamping block	For mounting on Z-axis (LES 5)	675015 9435

*n[_{max}] = 16,000 1/min



Linear tool change station SK 16, SK 20 and SK 30

5x linear tool changer
for SK 164x linear tool changer
for SK 205x linear tool changer
for SK 30

Merkmale

- simple, functional tool changer for SK 16, SK 20 and SK 30
- pneumatic rotary cylinder and end position monitoring for safe changing
- control via 5/2-way valve with integration in the safety circuit
- low-maintenance, stainless-steel design (powder-coated aluminium)
- variable positioning on the machine bench

Tool holders and max. shank diameter:

SK 16	SK 20	SK 30
Ø10 mm	Ø13 mm	Ø20 mm



Dimensions linear changer	SK 16 WxDxH [mm]	SK 20 WxDxH [mm]	SK 30 WxDxH [mm]
4x	–	500 x 224 x 253	869,5 x 240 x 320
8x	–	900 x 224 x 253	–
5x	451 x 178 x 208	985 x 224 x 302	1055,5 x 240 x 320
10x	–	1825 x 224 x 302	–

Order data

			Part No.
Linear tool change station	SK 16	4x (grid 72 mm), with hood and pneumatics / for EuroMod, FlatCom, erh. Portal, iSA 1200 W	239016 0041
		5x (grid 72 mm), with hood and pneumatics / for EuroMod, FlatCom, erh. Portal, iSA 1200 W	239016 0051
	SK 20	4x (grid 100 mm), with hood and pneumatics / for EuroMod, FlatCom, erh. Portal, iSA 2200 W	239011 0041
		8x (grid 100 mm), with hood and pneumatics / for FlatCom XL, iSA 2200 W	239011 0081
		5x (grid 170 mm), with hood and pneumatics / for FlatCom XL, iSA 2200 W	239011 0050
		10x (grid 170 mm), with hood and pneumatics / for FlatCom XL, iSA 2200 W	239011 0100
	SK 30	4x, with hood and pneumatics / for FlatCom XL, iSA 4000 (increased portal required)	239011 0045
		5x, with hood and pneumatics / for FlatCom XL, iSA 4000 (increased portal required)	239011 0055
Tool holder	SK 16	for collet type ER 16	239116 0001
	SK 20	for collet type ER 20	239172 0020
	SK 20-C	for collet type ER 20, version for internal cooling	239172 0021
	SK 30	for collet type ER 32	239131



Frequency converter SKC-Serie

for iSA motors



SKC 4000

SKC 1500

SKC 750

Features

- pulse width modulated devices with safety technology, three performance classes, compact design
- STO input (safe torque cut-off, in a case of failure the motor provides no torque)
- input voltage single-phase 230 VAC (SKC 750/1500) / three-phase 400VAC (SKC 4000)
- high load capacity 150 % overload for 60 sec.
- three-phase, vector-controlled control voltage, frequency 0 up to 1500 Hz
- fast deceleration of the spindle due to integrated brake resistor in the base
- disconnect able the EMC filter
- programmable inputs and outputs, relay outputs
- easy-to-use control unit to parameterize the spindle
- 95 operating and display parameters such as energy reduction of the spindle at idle run
- protection IP20
- type of control: PLC; 0 ... 10V; 0 ... 20 mA; with control panel;
CAN-Bus (additional module required)
- licence CE; C-Tick; UL

connection lead

various lengths as accessories



- 8-wire
- drag chain compatible
- external braiding and separately shielded pairs
- pre-fabricated

Motor side - M23 plug

Converter side - wire end bushings

Part No.: 392306 0300 (3 m)

Part No.: 392306 0500 (5 m)

Part No.: 392306 0800 (8 m)

Motor side - direct connection

Converter side - wire end bushings

Part No.: 392301 0300 (3 m)

Part No.: 392301 0500 (5 m)

Part No.: 392301 0800 (8 m)

Order data

		Part No.
SKC 750	for spindle motors iSA 750 and iSA 1200W	311707 6000
SKC 1500	for spindle motors iSA 750, iSA 1500 and iSA 2200W	311715 6000
SKC 4000	for spindle motor ES 325 HSK 25	311740 6500



Collets and device

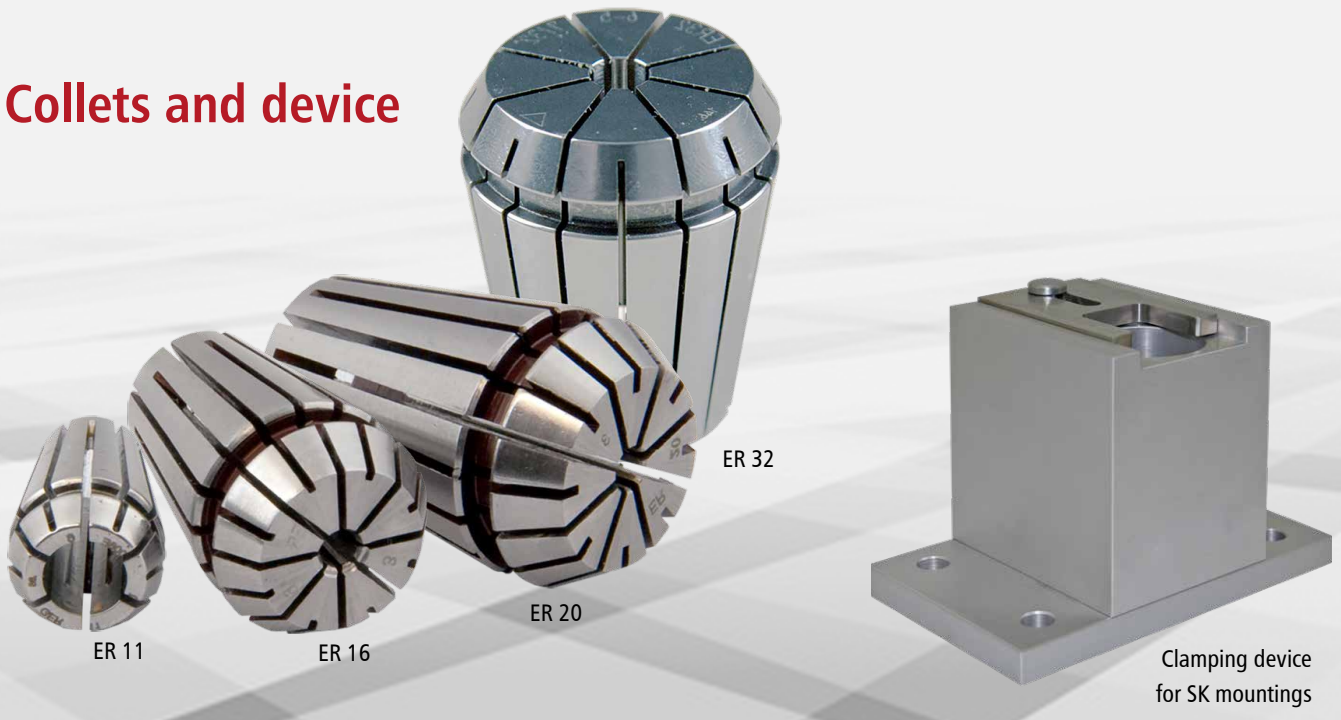

Collet sets

Type	for spindle motor	Clamping range [mm]	Part No.
ER 11*	iSA 900 W	1,0 - 7,0	239170 0001
ER 16**	iSA 750 / 1200 W	1,0 - 10,0	239171 0001
ER 20**	iSA 1500 / 2200 W,	1,0 - 13,0	239172 0001
ER 32**	ES 950 SK 30	3,0 - 20,0	239130 0000

Clamping device for SK holders

- Mounting device for SK20 tool holders
- Simple and safe clamping due to fork clamping sliders
- Mounting and dismantling of cutting tools
- Dimensions approx. 120 x 80 x 90 mm (WxDxH)

Item no.: 445000 2132

Collet ER 11*

for iSA 900 W

Ø [mm]	Art.-Nr.
1,0	239170 1000
1,5	239170 1500
2,0	239170 2000
2,5	239170 2500
3,0	239170 3000
3,5	239170 3500
4,0	239170 4000
4,5	239170 4500
5,0	239170 5000
5,5	239170 5500
6,0	239170 6000
6,5	239170 6500
7,0	239170 7000

Collet ER 16**

for iSA 750 / 1200 W

Ø [mm]	Art.-Nr.
1,0	239171 1000
2,0	239171 2000
3,0	239171 3000
4,0	239171 4000
5,0	239171 5000
6,0	239171 6000
7,0	239171 7000
8,0	239171 8000
9,0	239171 9000
10,0	239171 0100

Collet ER 20**

for iSA 1500 / 2200 W

Ø [mm]	Art.-Nr.
1,0	239172 1000
2,0	239172 2000
3,0	239172 3000
4,0	239172 4000
5,0	239172 5000
6,0	239172 6000
7,0	239172 7000
8,0	239172 8000
10,0	239172 0100
11,0	239172 0110
12,0	239172 0120
13,0	239172 0130

Collet ER 32**

for ES 950 SK 30

Ø [mm]	Art.-Nr.
3,0	239130 3000
4,0	239130 4000
5,0	239130 5000
6,0	239130 6000
7,0	239130 7000
8,0	239130 8000
9,0	239130 9000
10,0	239130 0100
11,0	239130 0110
12,0	239130 0120
13,0	239130 0130
14,0	239130 0140
15,0	239130 0150
16,0	239130 0160
17,0	239130 0170
18,0	239130 0180
19,0	239130 0190
20,0	239130 0200

Collet EX 16**

for ES 325 HSK 25

Ø [mm]	Art.-Nr.
1,0	477125 8010
1,5	477125 8015
2,0	477125 8020
2,5	477125 8025
3,0	477125 8030
4,0	477125 8040
5,0	477125 8050
6,0	477125 8060
7,0	477125 8070
8,0	477125 8080
9,0	477125 8090
10,0	477125 8100

* Diese Spannzangen sind in der Lage, auch Schäfte um Ø 0,5 mm reduziert genau zu spannen.

** Diese Spannzangen sind in der Lage, auch Schäfte um Ø 1,0 mm reduziert genau zu spannen.



Cutter box with milling cutters and Length measuring pushbutton



Cutter set

LMT 2

Length measuring pushbutton / Z zero point pushbutton

The pushbutton is used for the measurement of tool lengths by also offering an LED as a display for the operating status as well as a cable connection through an M8 connector. If used in connection with a magnetic plate, the pushbutton can also be used as a Z zero point pushbutton. This function is possible with the proNC software.

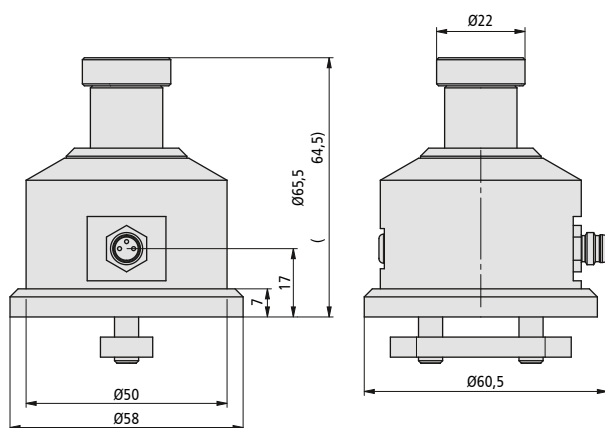

Cutter Box with milling cutters

- Aluminum single flute end mill
- solid carbide, 6 pieces

Order data



Part No.

Cutter set small	1,5 / 2 / 3 / 4 / 5 / 6 mm	239200 0003
Length measuring pushbutton LMT 2		239099 0015



CoolMin®



-  Air pressure
-  Warm air (max. 70° C)
-  Cold air (max. -20° C)

Tool and material cooling

Dry cutting is today the first choice for many machining tasks.

Hitherto, materials, tool wear and surface finish have often necessitated cooling with appropriate coolants / greases. This always means moisture. Even minimal moisture spray cooling causes unwanted effects such as the build-up of dirt and the adhesion of swarf to the cutting tool or to the working surface and can lead to the deterioration of the material surface structure, depending on the material being machined.

Our patented cooling method ensures adequate tool and surface cooling and reduces such effects to negligible levels.

This keeps the swarf dry and, depending on the material, easy to remove by either blowing or vacuuming.

Surfaces are therefore protected and, as a result of direct tool cooling, tool life is significantly increased (also suitable for tools with integrated cooling).

The main component of our cooling method is a cold air nozzle, which operates on the eddy current principle and separates warm air from cold.

The system is powered by air pressure alone (6 to 10 bar).

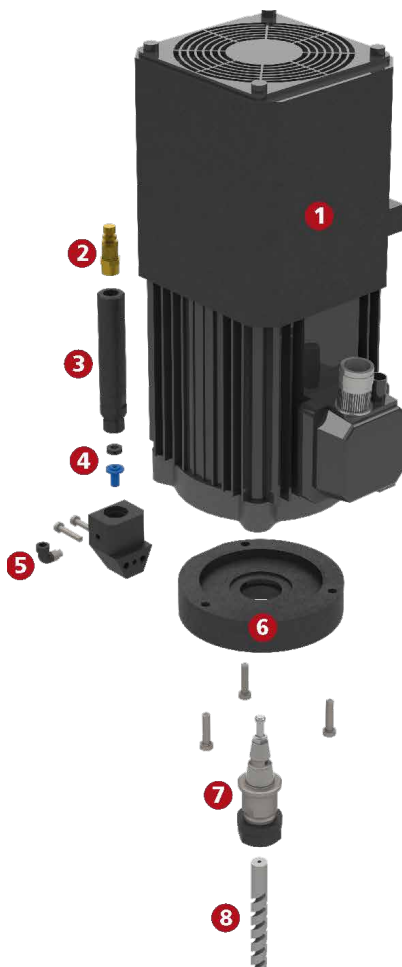

- 1 Spindle motor
- 2 Temperature controller
- 3 Hot air exhaust
- 4 Vortex nozzle with cold air exhaust
- 5 Compressed air feed
- 6 Cold air blower in synthetic material
- 7 Tool holder for internal cooling
- 8 Milling cutter for internal cooling



Functional principle

- 1 Compressed air feed
- 2 Flexible mating hose
- 3 Spindle motor
- 4 Temperature controller
- 5 Hot air exhaust
- 6 Vortex nozzle with cold air exhaust
- 7 Cold air supply in synthetic material
- 8 Collet

Technical specification

Compressed air feed	6 - 10 bar
Cold air exhaust	up to max. -25°C
Hot air exhaust	up to max. 70°C
Air consumption	approx. 150 l/min.

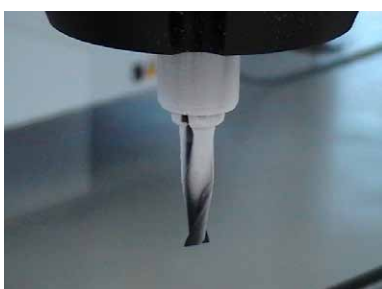

Tool, cooled by CoolMin® internal

CoolMin® external with mating hose

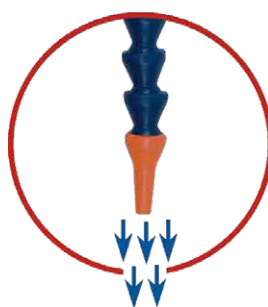

CoolMin® internal with tool cooling system

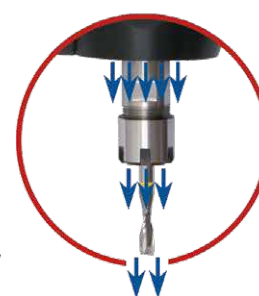

Optimum cold air flow (up to -25°C) for tool cooling and chip evacuation

Order data

CoolMin® internal		Part No.	see individual motors
CoolMin® external	incl. servicing kit and electrically-powered valve		239011 0117



mobile extraction systems

iAG 350



iAG 720



ME 1500



iAG 350

- special filter technology for dry, sticky dust and dust that tends to form clumps
- easy disposal of the collected dust thanks to the paper filter
- equipped with pre-separator, paper filter, cotton filter and dust class M filter cartridge
- three suction turbines with 230 volt power supply

Areas of application

- single-user extraction at machine and manual workstations
- cleaning work on machines, workshops and in production halls
- for sporadic use (alternating current version)

iAG 720

- low operating costs due to cleanable dust class M permanent filter cartridge
- mobility combined with high extraction performance
- tiltable filter housing for easy dust disposal
- suitable for almost all types of dust
- manual brush cleaning
- cleanable permanent filter cartridge
- special versions with different filter cartridges
- exhaust air connection (optional)
- special voltages (optional)
- floor cleaning and machine cleaning set possible

Areas of application

- single workstation extraction at machine and manual workstations
- free-flowing dusts (non-carcinogenic)
- dry dusts / chips
- dusts that are hazardous to health
- high chip/dust volumes

ME 1500

- suitable for continuous operation
- ErP-2015 compliant fan with IE3 motor, 5m mains cable
- ON/OFF motor protection switch
- 1x filter cartridge, category M according to IFA, polyester material
- rotary crank for manual filter cleaning
- monitoring of the minimum air volume flow via differential pressure switch
- powder-coated housing
- handle and 4x wheels to move the dust extractor if necessary
- large dust collection container (190 liters) with inspection window
- lifting/lowering mechanism for user-friendly emptying of the dust collection container
- suction nozzle Ø140mm.

Optional: modules and accessories

- downstream: Silencer
- downstream: H-13 filter
- filter cartridge in antistatic and/or PTFE version
- electrical components for ON/OFF by main machine
- frequency converter
- ATEX-compliant design for installation in AtEx zone 22
- type examination for wood dust
- sheet steel and spiral ducts

Dimensioned drawings

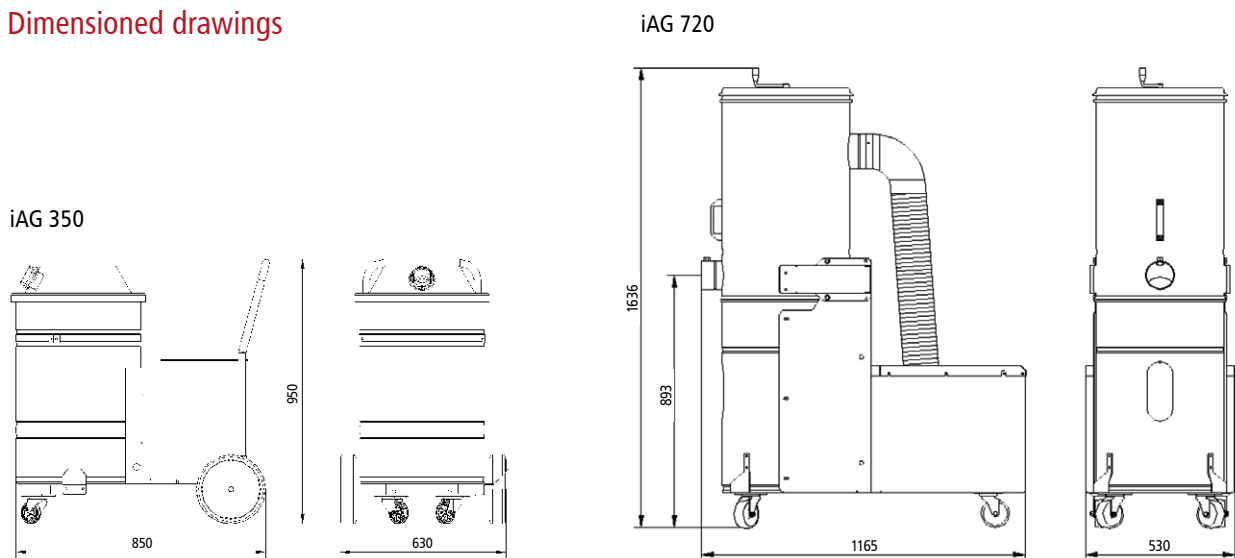

Technical and ordering data

	iAG 350	iAG 720	ME 1500
Voltage (V)	230	230	400
Motor (kW)	3 x 1,0	1,3	2,2
Max. negative pressure (Pa)	22.000	2.800	-
Max. airflow (m ³ /h)	350	720	1500
Filter surface (m ²)	3	3,5	9
Number of filter elements	1	1	1
Filter material	„M“-classified		
Filter cleaning	manual brush cleaning		Manual by means of rotary crank
Weight (kg)	41	120	160
Intake diameter (mm)	50	100	140
Dust collection bin (l)	70	100	190
Dimensions L x W x H (mm)	630 x 660 x 950	530 x 1165 x 1636	780 x 1160 x 1580
Scope of delivery	incl. hose 50 mm (L = 5 m) and mounting clamps		-
Part no.	239012 0036	239012 0030	445000 2193

Accessories

Hose	Ø 80 mm, L = 5 m Part no.: 639012 0004	
Mounting clamp	up to 170 mm, Part no.: 639012 0008	
Reduction	-	(Ø 100 / 80 mm) Part no.: 639012 0006

Dust extraction devices for iSA motors

Extraction head
(brush of horse-hair, optional ESD)



Extraction device

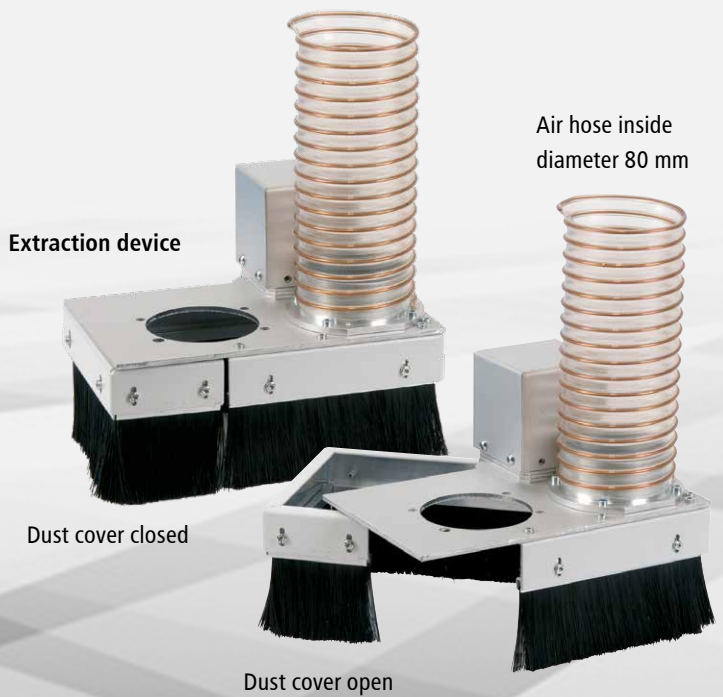

Air hose inside diameter 80 mm

Dust cover closed

Dust cover open

Extraction device and extraction head

The isel dust and chip extraction units are accessory components for milling spindles from isel Germany. They are used for the extraction of light dusts and chips during dry machining.



Order data	for spindle motor		Part No.
Extraction device	iSA 750	prepared for hose 38 mm, manual opening	239012 0000
	iSA 1200 W		on request
	iSA 1500	prepared for hose 80 mm, manual opening	239012 0001
	iSA 2200 W	prepared for hose 80 mm, automatic opening	239012 0002
		with external CoolMin, prepared for hose 80 mm, manual opening	239012 0003
	ES 325 HSK 25	prepared for hose 80 mm, automatic opening	239012 0016
Extraction head	iSA 750	with external CoolMin, prepared for hose Ø 50 mm, manual opening	239012 0012
	iSA 1200 W	prepared for hose Ø 50 mm, manual opening	239012 SDU6032
	iSA 1500	with external CoolMin, prepared for hose Ø 50 mm, manual opening	239012 SDU0435
	iSA 2200 W	prepared for hose Ø 50 mm, manual opening	239012 SDU2355
	iFM 1000 ER	prepared for hose Ø 50 mm, manual opening	239012 SDU8950
	iFM 1000 WS	prepared for hose Ø 50 mm, manual opening	239012 SDU9459

Minimum volume coolant misting system



The minimum volume coolant misting system works according to the principle „less is more“. A cooling lubricant-air mixture is used, which prevents the generation of frictional heat through optimum lubrication. The remaining heat is dissipated via the tool and the chip. The cooling lubricant must be metered and directed to the tool in a process-safe manner. This requires a high-precision nozzle technology that enables the application of minimal quantities of lubricant.

The minimum volume coolant misting system reduces lubricant consumption to an absolute minimum while keeping environmental impact to a minimum.

Features

- aluminium pressure vessel
- with 1 or 2 adjustable nozzles, includes 1 liter of spray oil
- liquid level control
- valve unit with solenoid valves
- precision coaxial spray head
- ball joint extension
- nozzle connection package with fittings for medium and spray air
- pressure reducer to adjust the container pressure

Advantages

- Increase in productivity
- Improvement of tool life
- clean workpieces with better surfaces
- environmentally friendly technology
- lower storage costs for media
- lower cleaning costs for machines and workplaces

Application areas

- Drilling
- Milling
- Engraving
- High speed machining
- Deep hole drilling

Order data

Minimum volume coolant misting system	with one flexible nozzle, includes 1 l spray oil
	with two flexible nozzle, includes 1 l spray oil

Part No.

429116 1000
429116 2000

Our customers and the projects we realize for them are as diverse as our services. We present a small selection of our references here:



Branches of the company isel

With branches in China, Hungary, and the USA as well as numerous partners in Germany, Europe and worldwide, we are close by at any time.

isel USA, Inc.

69 Bloomingdale Road
USA, Hicksville, New York 11801

Phone: +1 516 / 595 7497
Fax: +1 516 / 595 7498

www.isel.com/en

isel (Suzhou) Automation Co.,Ltd

No.411 Jianlin Road SND,
CN-215151 Suzhou

Phone: +86 512 / 684 191 25
Fax: +86 512 / 666 735 56

www.isel.com/cn

isel Hungaria Kft.

József A. utca 38
H-8200 Veszprém

Phone: +36 88 / 406 682
Fax: +36 88 / 568 030

www.isel.com/hu

Distribution for:

Bulgaria, Serbia, Montenegro, Bosnia, Herzegovina, Croatia, Slovenia, Slovakia, Czech Republic, Poland, Baltic States (Estonia, Latvia, Lithuania), Ukraine, Belarus, Moldova, Kazakhstan, Georgia

Are you interested in "systems" and "components"?

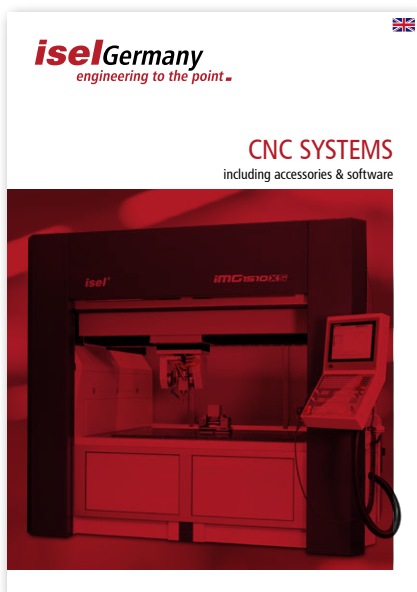

You can find our terms and conditions on our website www.isel.com



advanced
mechatronics

Spindle Motors

isel Germany GmbH

Bürgermeister-Ebert-Straße 40

D-36124 Eichenzell

Tel: +49 (0) 66 59 / 981 - 700

E-Mail: info@isel.com

www.isel.com

Aalberts advanced mechatronics

www.aalberts-am.com

iselGermany